

LT-300 INTRODUCTION

The LT-300 is a timing module capable of enabling a pump motor to run when an electrical signal is received. The pump run time can be set from 0.5 seconds to 12 minutes and is easily adjusted. Pump voltages can range from 24 to 240 volts AC or DC. Many different pump sizes and configurations are available. Consult your nearest Knight representative for details.

LT-300 OPERATION

- (1) For AC output devices, the LT-300 accepts input power ranging from 24 to 240 VAC and "switches" this voltage to output terminals marked COM and OUT (AC OUT). For example; a 115 VAC motor can be connected to the COM and OUT terminals if 115 VAC is applied to the 24-240VAC power input terminals.
- (2) For DC output devices, such as a 24 VDC motor, the positive side of the motor is connected to the DC OUT (+) terminal, and the negative side is connected to the DC OUT (-) terminal. 24 VAC should be applied to the 24-240 VAC power input terminals (the circuit board will convert AC to DC).
- (3) The minimum and maximum run time range of the pump (or other output device) is determined by selecting a jumper on the left side of the LT-300. The potentiometer (also called a "pot") on the board adjusts the actual time within the selected range. Choose a range that's closest to your desired run time -- this will make setting the time easier and more accurate. Jumper settings for time ranges are as follows:

JP1 selects time range from .5 sec. to 10 sec.

JP2 selects time range from 2 sec. to 45 sec.

JP3 selects time range from 5 sec to 3 min.

JP4 selects time range from 15 sec to 12 min.

- (4) Activation of the LT-300 is possible through any one of three methods.
 - Terminals marked DET and SIG (24-240VAC) accept a signal voltage from 24-240 volts (AC or DC) and, when received, activate the pump or output device for the set time set.
 - The signal terminals can be connected to the main power input wires, allowing the output device to "autostart" when main power is received. (NOTE: Only one pair of signal wires can be connected to the LT-300 signal input terminals).
 - An external start switch can be used to enable the LT-300 (see wiring diagram for details).
- (5) The output voltage of the LT-300 can be selected to be "on" or "off" during the activation time. This feature is set via the N/O and N/C jumpers labeled JP5 and JP6. For a pump or other device to be "on" during the activation time, set the LT-300 for N/O (normally open, or "off") operation by installing jumper JP6. To set the LT-300 to be "off", set the LT-300 for N/C (normally closed, or "on") operation by installing JP5.



CAUTION: Wear protective clothing and eyewear when dispensing chemicals or other materials. Observe safety handling instructions (MSDS) of chemical manufacturers.



CAUTION: To avoid severe or fatal shock, always disconnect main power when servicing the unit.

LT-300 INSTALLATION

- (1) Ensure that the main power input to the LT-300 is between 24-240 volts (AC or DC). Ensure that the pump voltage (or other output device) matches the main power input. Connect main power to the 24-240 VAC (POWER IN) terminals, and connect the pump to the COM and OUT (AC) or + and - (DC) terminals.
- (2) If a signal will be used, connect 24-240 volt (AC or DC) signal wires to the terminals marked DET and SIG. If "autostart" is desired, connect these terminals to the 24-240VAC (POWER IN) terminals.
- (3) Select the N/O or N/C operation mode as described previously in OPERATION, step #5.
- (4) Select the time range and time as described previously in OPERATION, step #3.
- (5) Press the prime switch on the LT-300 to prime the pump — the pump will run for the set time and then shut off.

Note that the LED illuminates when the device is on. If the run time needs to be changed, make adjustments to the pot (clockwise to increase, counter-clockwise to decrease) and prime again to check. You may need to use a different time range (set with jumpers) if the desired time can't be achieved with the range selected presently.

- (6) If an external start switch will be used, connect according to the wiring diagram in this manual.

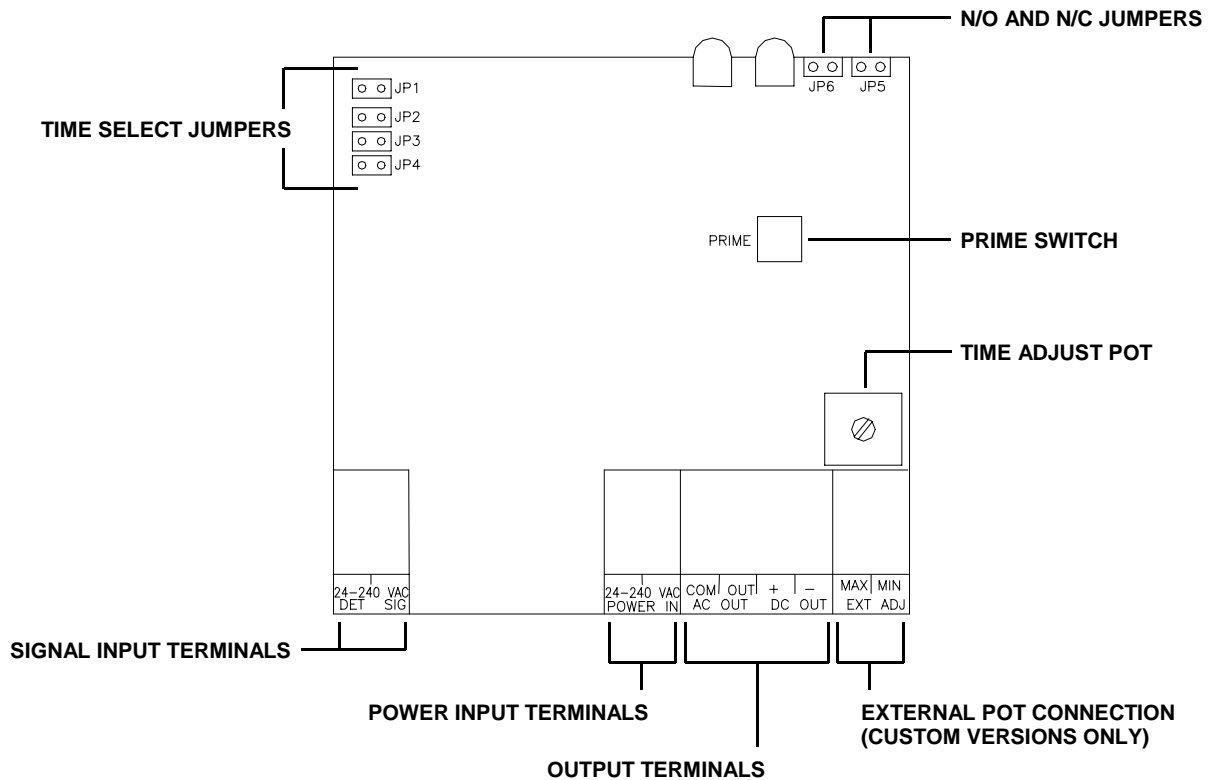

WIRING DIAGRAM

TYPICAL WIRING DIAGRAM

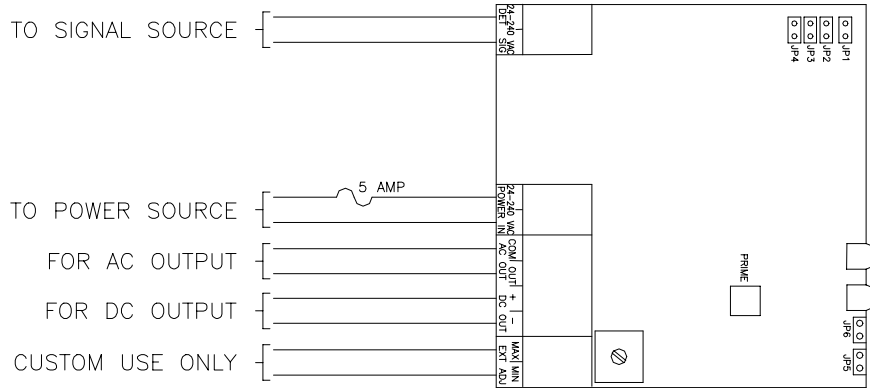

WIRING FOR "PUSH TO START" OPERATION

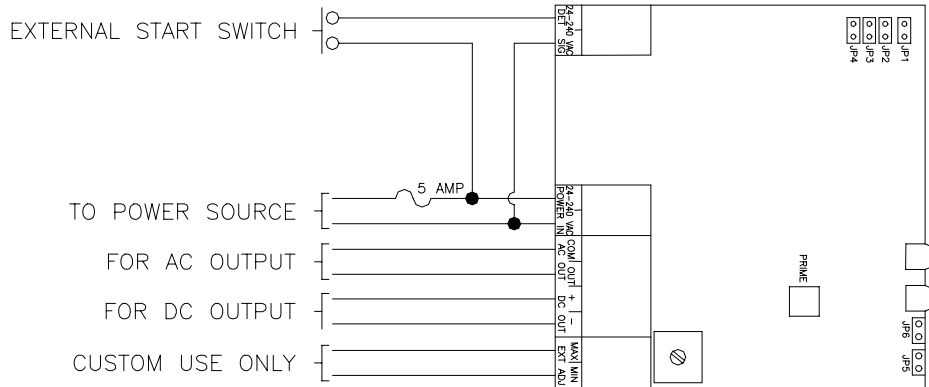

WIRING FOR "AUTO-START" OPERATION

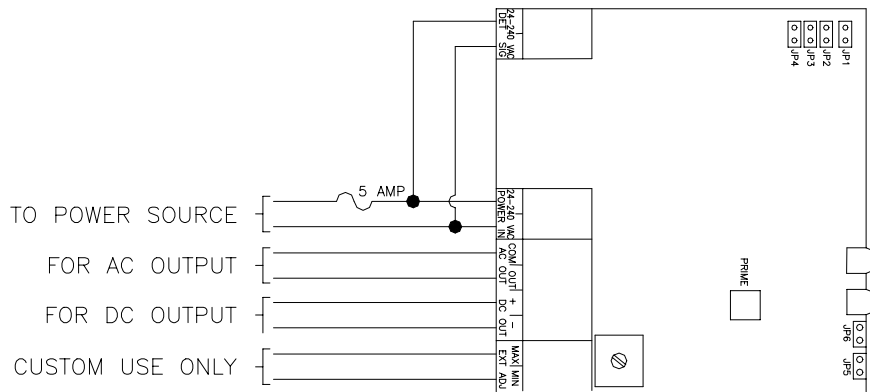

DISCLAIMER

Knight LLC does not accept responsibility for the mishandling, misuse, or non-performance of the described items when used for purposes other than those specified in the instructions. For hazardous materials information consult label, MSDS, or Knight LLC. Knight products are not for use in potentially explosive environments. Any use of our equipment in such an environment is at the risk of the user, Knight does not accept any liability in such circumstances.

WARRANTY

All Knight controls and pump systems are warranted against defects in material and workmanship for a period of ONE year. All electronic control boards have a TWO year warranty. Warranty applies only to the replacement or repair of such parts when returned to factory with a Knight Return Authorization (KRA) number, freight prepaid, and found to be defective upon factory authorized inspection. Bearings and pump seals or rubber and synthetic rubber parts such as "O" rings, diaphragms, squeeze tubing, and gaskets are considered expendable and are not covered under warranty. Warranty does not cover liability resulting from performance of this equipment nor the labor to replace this equipment. Product abuse or misuse voids warranty.

KNIGHT LLC, A Unit of IDEX Corporation

World Headquarters: 20531 Crescent Bay Drive, Lake Forest, CA 92630-8825 (USA) TEL: 949-595-4800, FAX: 949-595-4801, www.knightequip.com

Atlanta Branch: 415 Gees Mill Business Court NE, Suite 200 Conyers, GA 30013 USA TEL: 770-760-8777 FAX: 770-761-0199	Toronto Branch: 2880 Argentia Road, Unit 6 Mississauga, Ontario L5N 7X8 Canada TEL: 905-542-2333 FAX: 905-542-1536	London Branch: #15 Brunel Centre Newton Road, Crawley West Sussex UK RH10 9TU TEL: 44-1293-615570 FAX: 44-1293-615585	Sydney Branch: Unit 28, 317-321 Woodpark Rd., Smithfield NSW Australia 2164 TEL: 61-29-725-2588 FAX: 61-29-725-2025	Amsterdam Branch: Marssteden 68 7547 TD Enschede The Netherlands TEL: 31-53-428-58-00 FAX: 31-53-428-58-09
---	---	--	--	---