

KP1H

KNIGHT PROPORTIONING

INSTRUCTION MANUAL

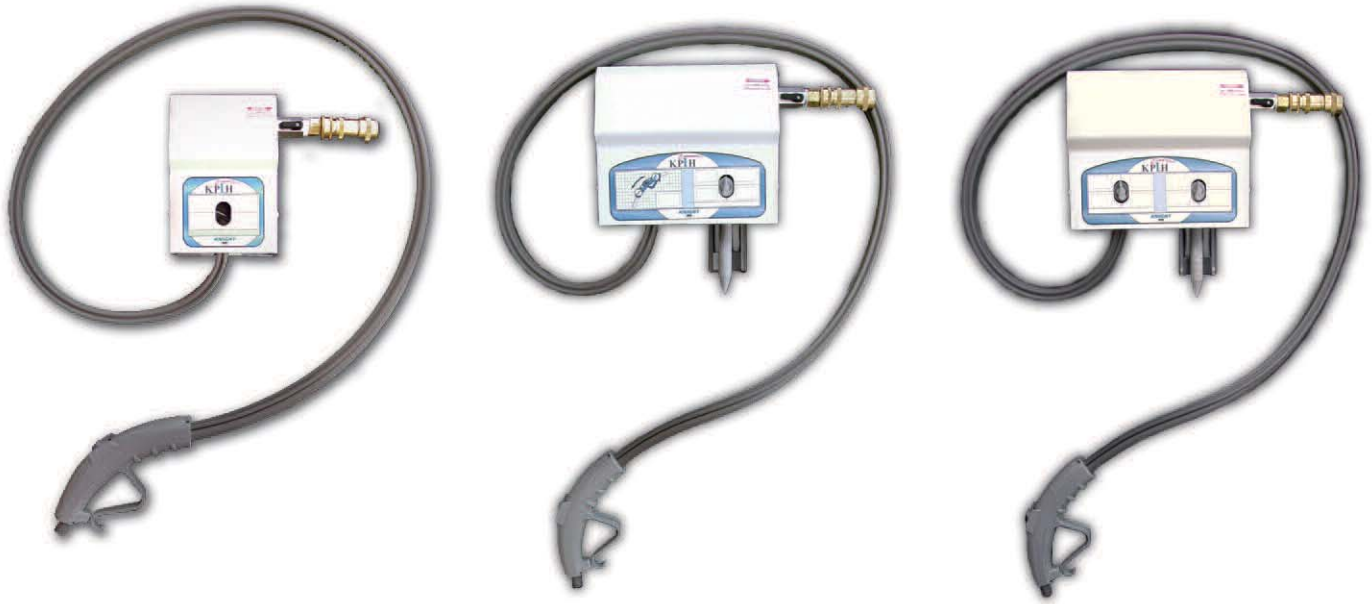

Table of Contents

Introduction

Theory of Operation	1
Specifications	1

KP1H Components	2
------------------------------	----------

Installation and Assembly

Single Proportioner Installation	4
KP1H Complete Installation	6
Multiple Proportioner Installation	8
KP1H Mixing Center Installation	9
Changing Product Configurations	12

Dilution Ratio Chart	14
-----------------------------------	-----------

Calibrating Product Ratios	14
---	-----------

Dial 4 Selector Positioning	14
--	-----------

Changing Flow Rates	15
----------------------------------	-----------

Pressure Regulation	16
----------------------------------	-----------

Troubleshooting	16
------------------------------	-----------

Maintenance	17
--------------------------	-----------

Warranty	17
-----------------------	-----------

DISCLAIMER

Knight LLC does not accept responsibility for the mishandling, misuse, or non-performance of the described items when used for purposes other than those specified in the instructions. For hazardous materials information consult label, MSDS, or Knight LLC. Knight products are not for use in potentially explosive environments. Any use of our equipment in such an environment is at the risk of the user, Knight does not accept any liability in such circumstances.

Introduction

The Knight KP1H is a chemical proportioning system uniquely engineered to be both versatile and scalable. The KP1H system is built as a single product bottle or bucket fill dispenser, or multiple product Dial 4 dispenser. Its modular design allows the installer to convert from one product configuration to another (6 different configuration capability) with only a few changes of snap-on parts. Each KP1H proportioning unit can be linked together to form a daisy chain with an unlimited number of configurations. The KP1H system easily adapts to the changing needs of any institutional or industrial cleaning application.

The KP1H provides two means for dispenser activation. The revolutionary "One-Hand" filling of spray bottles features an easy to use bottle actuator that makes bottle fill easier than ever. For customers who prefer "Locking Button" operation to fill buckets or bottles, the "Easy Lock" button can be added.



Flex Gap™ and Aire Gap™ backflow devices with different flow rates are installed to meet plumbing code requirements for most city, state, county or worldwide regulations.

KP1H MIXING CENTER

The KP1H Center is an integrated "turn-key" dispensing solution with the KP1H Proportioners mounted on a durable stainless steel locking enclosure with a removable drip tray. The center is built as a single container or double container unit. Each center holds two KP1H proportioners that can dispense from up to five different products.

THEORY OF OPERATION

The KP1H will activate and dispense the chemicals at the proper dilution rate when the button or actuator is pressed and will stop when the actuator is released.

- **Button activated units:** The "easy touch" button operates like a switch. A straight push instantly activates the valve for intermittent feed. Pushing the button in and upward "locks" the button in place for bucket fill.
- **Bottle activated units:** Allows the operator to insert the spray bottle over the pre-formed Fill Tube and push in the actuator arm to start the dispensing process, much like a self-serve beverage machine.
- **KP1H Dial 4 units:** Allows from 1 to 4 chemicals to be dispensed, each with its own dilution rate. The operator turns the dial selector knob to the chemical to be dispensed and activates the unit using the bottle or button actuator.

SPECIFICATIONS

WATER PRESSURE

Max: 125 PSI (8.6 BAR)
Min: 25 PSI (1.7 Bar)
Opt.: 30 – 60 PSI (2 to 4 Bar)

WATER TEMPERATURE

Max: 140° F / 60° C

DIMENSIONS

KP1H Complete Single	12 ^{1/4} "H x 6 ^{3/4} " W x 3 ^{3/4} " D (31 cm H x 17 cm W x 10 cm D)
KP1H Complete Dual	12 ^{1/4} "H x 10 ^{3/4} " W x 3 ^{3/4} " D (31 cm H x 27 cm W x 10 cm D)
KP1H Complete Mixing Station	14 ^{3/4} "H x 13" W x 37 ^{1/2} " D (37.47 cm H x 33 cm W x 95.25 cm D)
Button Activated KP1H	8 ^{1/4} " H x 6 ^{1/2} " W x 3 ^{1/4} " D (21 cm H x 16.5 cm W x 8.25 cm D)
Bottle Activated KP1H	12 ^{1/4} "H x 6 ^{1/2} " W x 3 ^{1/4} " D (31 cm H x 16.5 cm W x 8.25 cm D)
4 Product Center	13 ^{1/2} " H x 25" W x 7" D (34 cm H x 64 cm W x 18 cm D)
1 Product Center	13 ^{1/2} " H x 12 ^{1/2} " W x 7" D (34 cm H x 32 cm W x 18 cm D)

MATERIAL OF CONSTRUCTION

All parts that are in contact with chemicals are made of glass filled polypropylene, viton, and EPDM.

CHEMICAL COMPATIBILITY

Contact factory for compatibility of all parts.

VACUUM

28" (.93 Bar) at 50 PSI (3.4 Bar) (Note: Fluctuating water pressure will cause vacuum to change)

KP1H Components

Product names make installation and assembly instructions easier to follow. It will also allow our Technical and Customer Support Team to assist you with your questions and replacement part orders. Depending on the proportioner purchased, not all components listed below are included. Please use the listed part numbers for purchasing replacement parts.

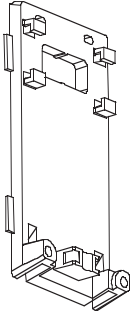

Backing Plate
P/N 7630021

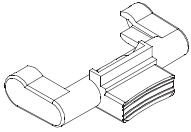

Actuator Button
P/N 7630028

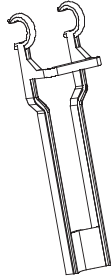

Actuator Arm
P/N 7630027

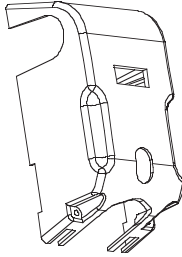

Cover
P/N 7630020-DB

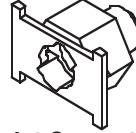

Inlet Connector
Female Bayonet x
Male Thread
(right side water inlet)
P/N 7630034

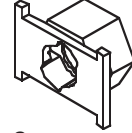

Cap
Female Bayonet
(right side)
P/N 7630035

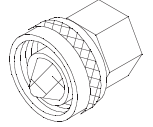

3/4" Garden Hose Adapter
Water Inlet Stations
P/N 0300209
Water Inlet Centers
P/N 1600628
Europe
P/N 0300209-EU
Australia
P/N 0300209-AU

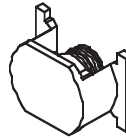

Cap
Male Bayonet
(left side)
P/N 7630033

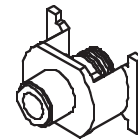

Inlet Connector
Male Bayonet x Male Thread
(left side water inlet)
P/N 7630032

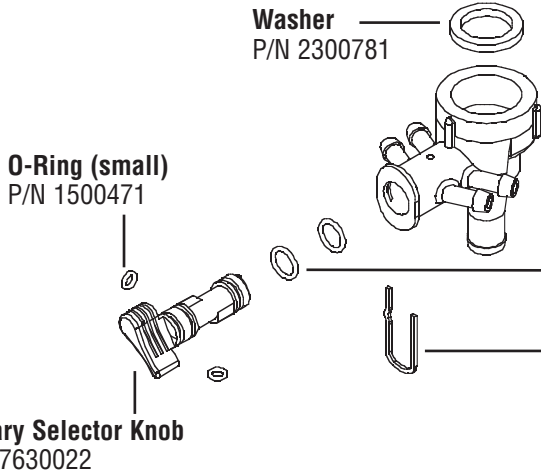

O-Ring (small)
P/N 1500471

Washer
P/N 2300781

Dial 4 Selector- Flex Gap
1GPM - P/N 7630023-1
4GPM - P/N 7630023-4
Aire Gap Body
P/N 7630055

O-Ring (large)
P/N 1500483

Rotary Selector Clip
P/N 7630008

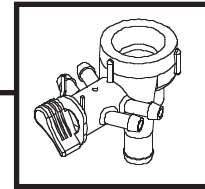

Dial 4 Selector Assembly
Flex Gap
1 GPM - P/N 7630029-1
4 GPM - P/N 7630029-4
Aire Gap
1 GPM - P/N 7630056-1
3 GPM - P/N 7630056-3

Venturi Body
Flex Gap
1GPM - P/N 7407226
4GPM - P/N 7407227
Aire Gap
P/N 7407200-G

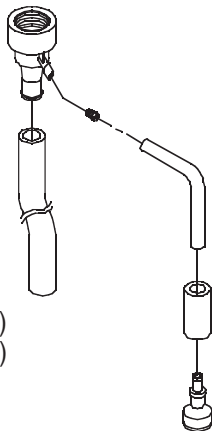

Bucket Fill Hose
P/N 7026871 (Flex Gap)
P/N 7026892 (Aire Gap)

Metering Tip Set
P/N 2201200

Supply Tube
P/N 7025842

Ceramic Weight
P/N 0300519

Footvalve
P/N 2201225 (Viton)
P/N 2201225-EP (EPDM)

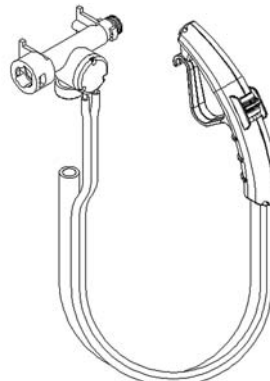

Valve Assembly and Bucket Fill Assembly for KP1H Complete
P/N 7630146



Tube Spring
P/N 7630045



Pistol Grip
P/N 0700250



Fill Tube Spout
Aire Gap (All)
Flex Gap (D4 only)
P/N 7630041-A
Flex Gap (Single Prod Only)
P/N 7630041-F

KP1H Components

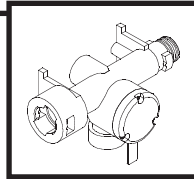
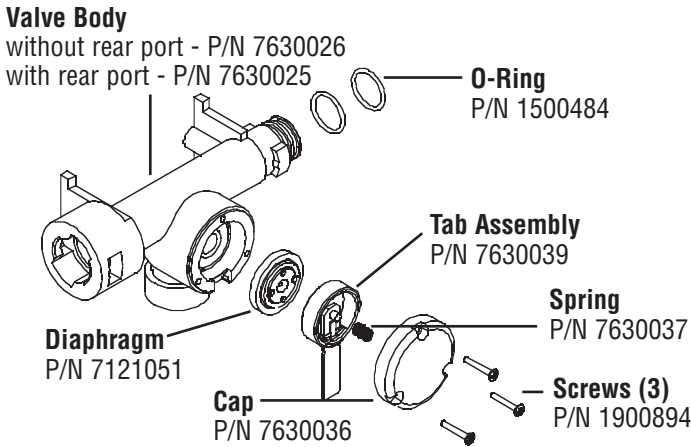
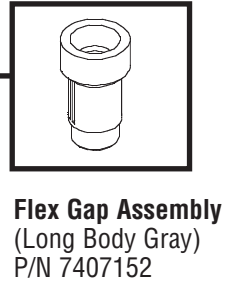
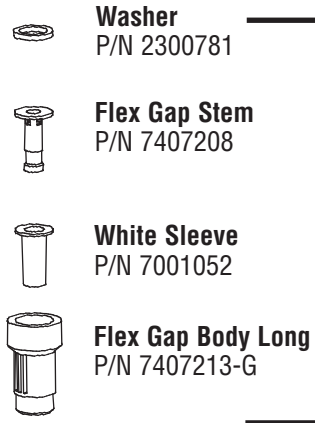
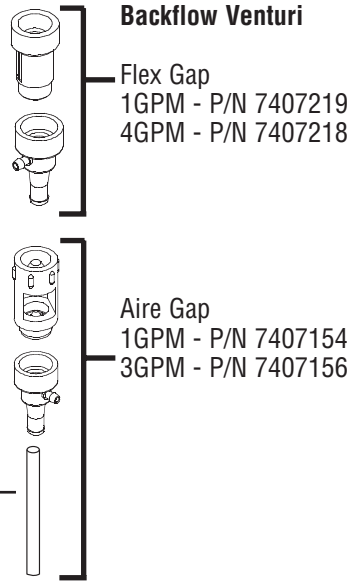
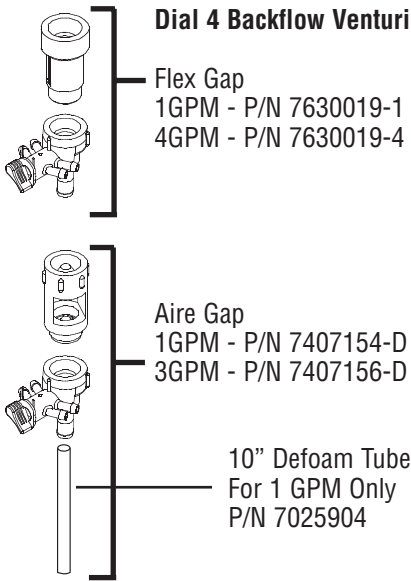

Valve Assembly with Rear Port
P/N 7630042
or
Valve Assembly without Rear Port
P/N 7630043

KP1H Complete LABELS



P/N 1200289



P/N 1200290



P/N 1200288

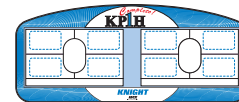

P/N 1200287



P/N 12104561

KP1H LABELS

Label designs may be different for custom KP1H systems.



Single Product without Button
P/N 1201388



Single Product with Button
P/N 1201388-B



Dial 4 without Button
P/N 1201388-D



Dial 4 with Button
P/N 1201388-DB

English	Español (América)	Español (Europa)	Nederlands	Deutsch	Français	Italiano
Glass Cleaner	Limpador de Vidrio	Limpia-Cristales	Glas Reiniger	Glas Reiniger	Nettoyant Pour Verre	Prodotto Lavavetro
Disinfectant Cleaner	Limpador Desinfectante	Desinfectante	Desinfectant Mittel	Desinfectant Mittel	Nettoyant Désinfectant	Prodotto Disinfettante
Pot & Pan Soak	Enjuague para Ollas y Cacerolas	Adiuvante para Ollas y Cacerolas	Bewandlingstopt en Pannen	Einweichtopf und Pfannen	Rinçage Des Marmites Et Casseroles	Prodotto per Anodiati Pentame
All Purpose Cleaner	Limpador Multiuso	Multususo	Aller Reiniger	Aller Reiniger	Nettoyant Multi-Usages	Prodotto Multi-Usi
Odor Counteractant	Contrarrestante de Olores	Neutralizante de Olores	Gier Neutralisator	Serch Neutralisator	Eliminateur D'Odours	Prodotto Deodorante
Tub & Tile Cleaner	Limpador de Tinas y Azulejo	Limpador de Pordolinas y Azulejos	Badkamer Reiniger	Badzimmer Reiniger	Nettoyant pour Baignoires Et Carrelage	Prodotto per Vassoi e Marmole
Silverware Soak	Enjuague para Platería	Adiuvante Cubertería	Bewandling Tafelzilver	Einweichtafelzilver	Rinçage De L'Argentaria	Prodotto per l'Argentaria
Floor Cleaner	Desengrasante para Ollas y Cacerolas	Desengrasante para Ollas y Cacerolas	Vloer Reiniger	Boden Reiniger	Nettoyant Pour Sol	Lava Paviment
Degreaser Cleaner	Limpador de Fiecos	Limpador de Sábios	Oven Reiniger	Ofen Reiniger	Nettoyant Degreasant	Prodotto Sgrassante
Pot & Pan Detergent	Limpador Desengrasante	Desengrasante	Pfoten en Pannen Reiniger	Töpfe und Pfannen Reiniger	Dégraissant Pour Marmites Et Casseroles	Detergente per Pentame
Sink Sanitizer	Sanificante para Fregadero	Desinfectante para Fregadero	Waschtisch Desinfektant Mittel	Spülbecken Desinfektors Mittel	Assainissant Pour Eviers	Prodotto per Lavabi

Large Chemical Labels P/N 1200128

Large Chemical Labels
P/N 1200128
(see p. 19)

Small Chemical Labels P/N 1200130 (see p. 18)

English	Español (América)	Español (Europa)	Nederlands	Deutsch	Français	Italiano
Glass Cleaner	Limpador de Vidrio	Limpia-Cristales	Glas Reiniger	Glas Reiniger	Nettoyant Pour Verre	Prodotto Lavavetro
Disinfectant Cleaner	Limpador Desinfectante	Desinfectante	Desinfectant Mittel	Desinfectant Mittel	Nettoyant Désinfectant	Prodotto Disinfettante
Pot & Pan Soak	Enjuague para Ollas y Cacerolas	Adiuvante para Ollas y Cacerolas	Bewandlingstopt en Pannen	Einweichtopf und Pfannen	Rinçage Des Marmites Et Casseroles	Prodotto per Anodiati Pentame
All Purpose Cleaner	Limpador Multiuso	Multususo	Aller Reiniger	Aller Reiniger	Nettoyant Multi-Usages	Prodotto Multi-Usi
Odor Counteractant	Contrarrestante de Olores	Neutralizante de Olores	Gier Neutralisator	Serch Neutralisator	Eliminateur D'Odours	Prodotto Deodorante
Tub & Tile Cleaner	Limpador de Tinas y Azulejo	Limpador de Pordolinas y Azulejos	Badkamer Reiniger	Badzimmer Reiniger	Nettoyant pour Baignoires Et Carrelage	Prodotto per Vassoi e Marmole
Silverware Soak	Enjuague para Platería	Adiuvante Cubertería	Bewandling Tafelzilver	Einweichtafelzilver	Rinçage De L'Argentaria	Prodotto per l'Argentaria
Floor Cleaner	Desengrasante para Ollas y Cacerolas	Desengrasante para Ollas y Cacerolas	Vloer Reiniger	Boden Reiniger	Nettoyant Pour Sol	Lava Paviment
Degreaser Cleaner	Limpador de Fiecos	Limpador de Sábios	Oven Reiniger	Ofen Reiniger	Nettoyant Degreasant	Prodotto Sgrassante
Pot & Pan Detergent	Limpador Desengrasante	Desengrasante	Pfoten en Pannen Reiniger	Töpfe und Pfannen Reiniger	Dégraissant Pour Marmites Et Casseroles	Detergente per Pentame
Sink Sanitizer	Sanificante para Fregadero	Desinfectante para Fregadero	Waschtisch Desinfektant Mittel	Spülbecken Desinfektors Mittel	Assainissant Pour Eviers	Prodotto per Lavabi

Single Proportioner Installation

Proper installation will help you get the maximum performance and product life from your KP1H system. The following instructions will guide you through the installation of a single bottle fill, bucket fill, or Dial 4 Proportioner.

1. Remove the cover by loosening two screws near the bottom of the proportioner (screws do not need to be completely taken off). Then lift the cover up and out using the open slot at the top of the cover. **(Bottle Fill units have a fill tube spout under the cover, this should also be removed).**

Dial 4

To remove cover from a Dial 4 proportioner, the dial knob must be at the 12 o'clock position.

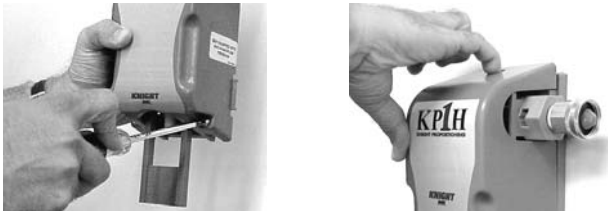

2. Mounting the proportioner is easier with the actuator arm removed. Remove the actuator arm by lifting up and pulling out on the actuator hook.



3. Mount the unit near a water source and no more than 5 feet from the floor. Depending on the wall surface, use toggle bolts, masonry screws, or wall anchors to mount the unit on the wall.



4. Connect water source to water inlet fitting adapter. (Refer to page 5 to change water inlet location).



Note: Avoid extremely hot water and very high pressure.

Important note: If proportioner is connected to a janitor's sink with an atmospheric vacuum breaker, a special connection kit is required by A.S.S.E. specification 1055. Failure to use this kit, or equivalent connection methods will invalidate the A.S.S.E. and I.A.P.M.O. (UPC) certification. Specify P/N 7600187 when ordering the kit

5. Remove the tie wrap on the backing plate. Attach the fill tube spout to the venturi with the spout opening facing away from you. Use the tie wrap to secure fill tube. (Excess tie wrap may be cut off).

1 GPM Aire Gap (OPTIONAL)

Attach 10" defoam tube to the venturi and route fill tube spout over the defoam tube. Cut the defoam tube as needed. For best result, cut defoam tube enough so that the end still touches the bottom of the spray bottle.

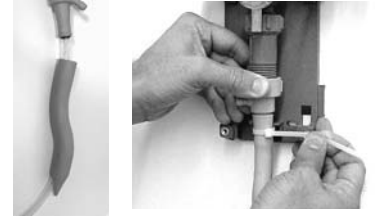

For bucket fill proportioner, attach bucket fill hose to the venturi and secure hose with the tie wrap. (Excess tie wrap may be cut off).

6. Thread the proper metering tip into the chemical inlet port on the side of the venturi body. (See p.14 for tip ratios.)



7. Hook the actuator arm back onto the proportioner. The actuator arm must be behind the chemical inlet and the fill tube spout.



8. Remove the 3/8" supply tube and tube spring from the accessory kit. Pull the supply tube through the opening at the bottom of the backing plate.

Twist the supply tube spring over the tube and attach it to the inlet barb of the venturi. Spring must be used to prevent tube from "kinking". (For Dial 4 setup, spring is not used.)



Single Proportioner Installation

Dial 4 Bottle Fill

For a Dial 4 Bottle Fill, attach the supply tubes to the chemical inlets, then separate the tubes with tie wraps to allow enough space under the actuator arm for it to depress all the way to the wall.

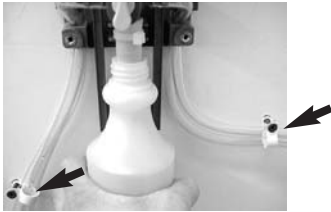

9. Take the ceramic weight from the accessory kit and slide it onto the free end of the supply tube. Then install the footvalve and insert the tube into your chemical container.



10. Place cover back onto the proportioner and use screws to secure in place.

Note: To eliminate chemical discharge onto wall, the pre-formed fill tube can be cut for a straight discharge. Be sure to cut tube at tangent point (last bend). This may cause a slight increased in foaming.

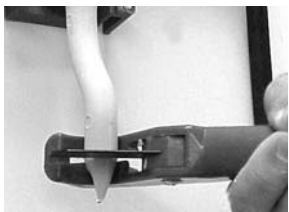

11. Add Chemical label as needed.



CHANGE THE WATER INLET POSITION

The water inlet is preassembled on the right side of the proportioner. Depending on the location of your water source, the inlet position can be changed to the left side.

1. Slide the whole valve assembly off the backing plate by pushing it to the right. Note* For KP1H Complete, remove the screws in the back of the case, Remove the clamp on the discharge hose.
2. Twist the right water inlet connector towards you until it stops, then pull off. The water inlet connector may come off easier if you twist and pull at the same time.

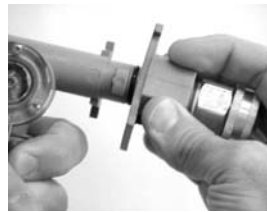

3. Remove the left inlet cap (cap x male bayonet) by twisting it away from you and pulling off.



4. Remove the right inlet cap (cap x female bayonet) and the left water inlet connector (female bayonet x male thread) from the accessory kit.

Take the inlet cap (cap x female bayonet) and match it to the notch on the right side of the valve. Then push the cap in and twist it away from you to lock into place.



Take the left water inlet connector and match it to the notch on the left side of the valve. Then push the inlet connector in and twist it towards you to lock into place.

5. Remove the water inlet adapter from the the inlet connector that it is attached to. Then take the inlet adapter and attach it to the left inlet connector you have just assembled.

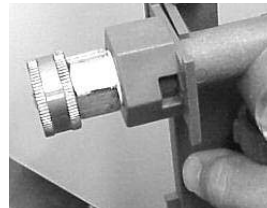

6. Re-attach the whole valve assembly and replace the cover as needed. Important: Replace the clamp on the discharge hose.

KP1H Complete Installation

Proper installation will help you get the maximum performance and product life from your KP1H Complete system. The following instructions will guide you through the installation of a single bottle fill, bucket fill, or Dial 4 Proportioner.

1. Remove the cover by loosening four screws on the side of the proportioner (screws do not need to be completely taken off). Then lift the cover.

Dial 4

To remove cover from a Dial 4 proportioner, the dial knob must be at the 12 o'clock position.

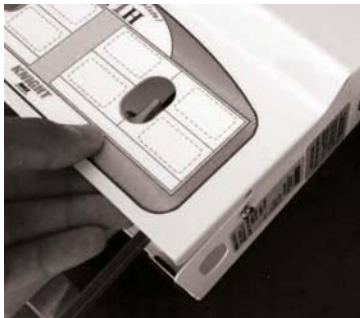

2. Mount the unit near a water source and no more than 5 feet from the floor. Depending on the wall surface, use toggle bolts, masonry screws, or wall anchors to mount the unit on the wall.



3. Connect water source to water inlet fitting adapter. (Refer to page 5 to change water inlet location).



Note: Avoid extremely hot water and very high pressure.

Important note: If proportioner is connected to a janitor's sink with an atmospheric vacuum breaker, a special connection kit is required by A.S.S.E. specification 1055. Failure to use this kit, or equivalent connection methods will invalidate the A.S.S.E. and I.A.P.M.O. (UPC) certification. Specify P/N 7600187 when ordering the kit

4. Thread the proper metering tip into the chemical inlet port on the side of the venturi body. (See p.14 for tip ratios.)



5. Remove the 3/8" supply tube from the accessory kit. Push the supply tube through the grommet at the bottom of the mounting plate. Attach the supply tubes to the inlet barbs of the venturi

Dial 4 Bottle Fill

For a Dial 4 Bottle Fill, attach the supply tubes to the chemical inlets, then separate the tubes with tie wraps to allow enough space under the actuator arm for it to depress all the way to the wall.

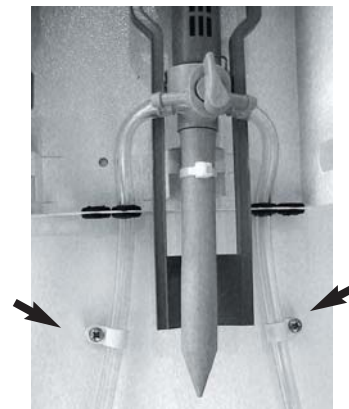

6. Take the ceramic weight from the accessory kit and slide it onto the free end of the supply tube. Then install the footvalve and insert the tube into your chemical container.



7. Place cover back onto the proportioner and use screws to secure in place.

Note: To eliminate chemical discharge onto wall, the pre-formed fill tube can be cut for a straight discharge. Be sure to cut tube at tangent point (last bend). This may cause a slight increase in foaming.

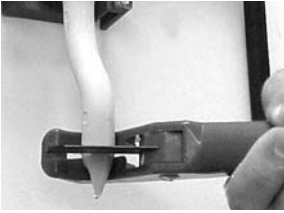

8. Add Chemical label as needed.

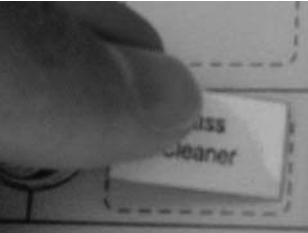

Note: Turn OFF water using Ball-Valve on Water Inlet when NOT in use.

Multiple Proportioner Installation

Bottle Fill, Bucket Fill, and Dial 4 proportioners can be linked together in any combination. There is no limit to the possibilities. To assemble multiple proportioners, follow the instruction below and always start from the left and add onto the right. Note: Use a lubricant (KTL-20 or equivalent) on the "O"-ring to make assembly easier.

1. Remove the cover of the first proportioner by loosening two screws at the bottom (screws do not need to be completely taken off). Then lift the cover up and out using the open slot at the top of the cover. (Bottle Fill units have a fill tube spout under the cover, this should also be removed).

Dial 4

To remove cover from a Dial 4 proportioner, the dial knob must be at the 12 o'clock position.



2. Slide the whole valve assembly off the backing plate by pushing it to the right.

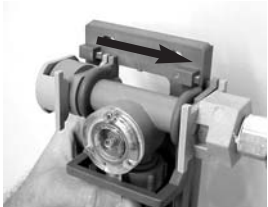

3. Twist the right water inlet connector towards you until it stops then pull off. The water inlet connector may come off easier if you twist and pull at the same time.



4. Remove the left inlet cap (cap x male bayonet) from the next proportioner by twisting it away from you and pulling off.



5. Connect the male bayonet from the first proportioner to the female bayonet of the second proportioner. When the notch of the two valves are lined up properly, simply push together and twist into place.

Continue with steps 1 through 5 until all valve assemblies are connected.

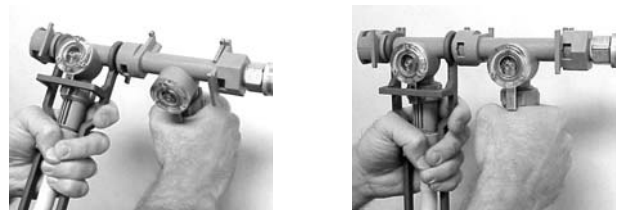

6. Slide the backing plates on one at a time (starting from the left) until all the backing plates are in place. Then follow steps 2 through 11 on pages 4 and 5 to finish the installation.

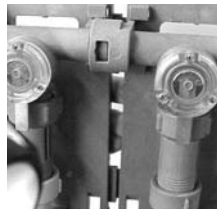

KP1H Mixing Center Installation

In the accessory kits, you will find some extra 8-32 nuts. These nuts will be used as "spacers" when mounting two KP1H Centers side-by-side. This will increase the spacing between the units and allow the doors to close more easily. The screws will also act as guides when lining up the units side-by side.

Mounting the Cases

1. Find a total of four 8-32 screws from the KP1H Center accessory kits. (Each kit contains two screws and four nuts)
 - Insert the screws through the mounting embosses from the inside of the case, as shown to the right.

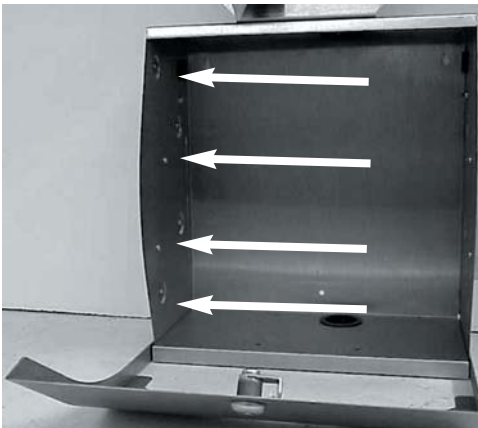

2. Thread on the four 8-32 nuts from the accessory kits, as shown to the right.
 - Tighten the nuts about 1/4 turn past hand-tight.

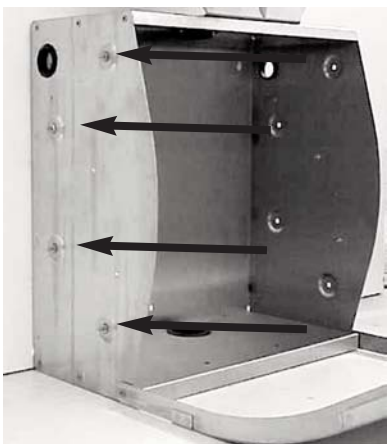

3. Align the screws with the corresponding holes in the mounting embosses of the second KP1H Center, as shown to the right.

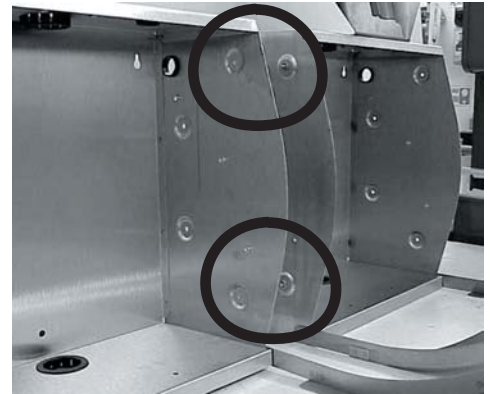

4. Find the four 8-32 nuts with star washers from the KP1H Center accessory kits.
 - Slide the two cabinets together, and thread on the nuts with the washers facing the case. Tighten the nuts securely and your done.

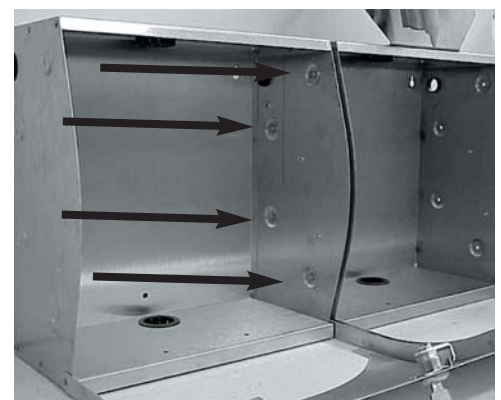

KP1H Mixing Center Installation

The KP1H Mixing Center is a one, two or four product chemical proportioning system designed to secure your chemical concentrates under lock and key. The following procedures will guide you to install the Mixing Center and KP1H assembly at your customer's site. Two installation scenarios are possible with the Mixing Center. (A) Mount the Proportioners on top of the Mixing Center. (B) Mount the KP1H and KP1H Drip Tray on the wall.

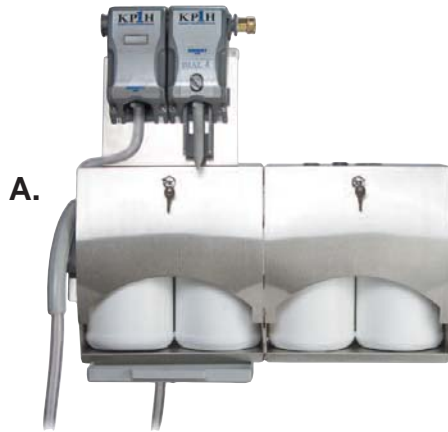

Mounting the Cases

1. Mount the Mixing Center Case near a water source at a height that is convenient for the user to dispense cleaning solutions and load chemical concentrates.

- Secure the cabinet to the wall using keyholes provided at the top of the case and single round hole located at the bottom.



- For four product installations, install the second Mixing Center Case alongside, below or on another wall as needed. Insert nut between the cabinets for spacing (refer to pg 9). Before mounting on wall, cases can be screwed together with screws and nuts.



2. Mount the easel to the case if the KP1H Proportioners are to be installed on the Mixing Center Top.



Install the KP1H Proportioners

3. Mount the KP1H to the Easel. (You must first remove the cover and the assembly from the KP1H backing plate.) Secure the backing plates with screws.

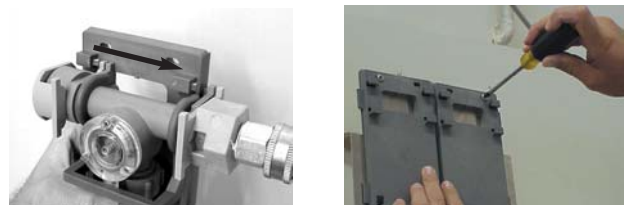

- For single proportioner installation, reinstall the KP1H assembly and secure it with tie wrap. Then follow the instructions on page 4 and 5 to complete the assembly of the proportioner.
- For two proportioner installation, connect the two KP1H assembly together (Refer to page 8). Then slide the assembly on to the backing plates and secure with tie wraps. Then follow the instructions on page 4 and 5 to complete the assembly of the proportioners.

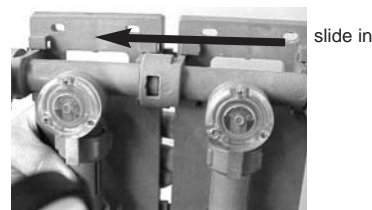

KP1H Mixing Center Installation

4. Install the bucket fill hose grip bracket on the side of the case.

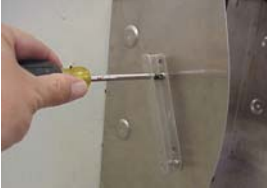

Connecting The Bucket Fill Hose

5. Connect 3/4" O.D vinyl bucket fill hose with flow restrictor over high flow venturi. The end closest to the plastic flow restrictor insert (single product Flex-Gap only) must be connected to the valve. Secure hose with tie wrap.



- Route the bucket fill hose above the mixing center door and along side panel as shown. Install plastic bucket fill hose retainer on side of mixing center case.



6. The KP1H Mixing Center is shipped with a plastic 3/4" MGHT x 3/8" barb elbow fitting. Use this fitting along with a standard 1/2" O.D. appliance hose to supply water to the KP1H Proportioner.

- Route the female end of the hose through the large hole in the top and bottom of the Mixing Center Case. Cut the male end of the hose off and push bare hose end over barb fittings as shown. Secure the hose with a stainless steel hose clamp to prevent leaks.



7. Route and connect the chemical inlet lines for the Dial 4 and bucket Fill through the holes in the top of the Mixing Center Case.



8. Mount Drip Tray to case bottom using screws and nuts provided.

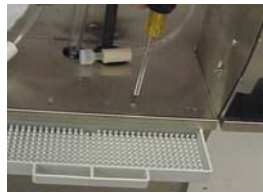

9. Attach 3/8" drain tube to the nipple on the Drip Tray and route the tube to a suitable drain or slop sink. Place your chemical container(s) in the Mixing Center Case.

10. Pressurize the system and test the system for leaks.



KP1H Complete Mixing Station Installation

The KP1H Complete Mixing Station is a one, two or four product chemical proportioning system designed to secure your chemical concentrates under lock and key. The following procedures will guide you to install the Mixing Station assembly at your customer's site.



Mounting the Cabinet

1. Mount the Mixing Center assembly near a water source at a height that is convenient for the user to dispense cleaning solutions and load chemical concentrates.
 - a. Attach the supplied joggle bracket onto the wall using the supplied wall mounting kit.



- b. Secure the cabinet to the wall by sliding down the male joggle bracket at the top of the case down onto the female joggle bracket on the wall.

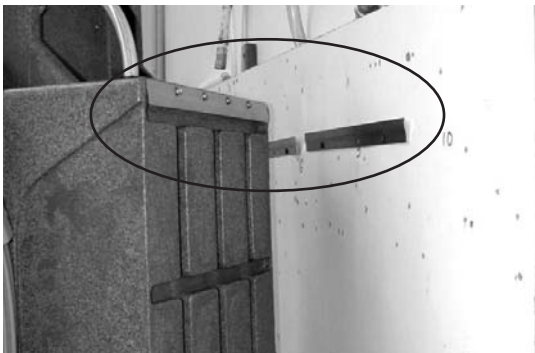

- c. Cabinet held by the joggle bracket shown below.

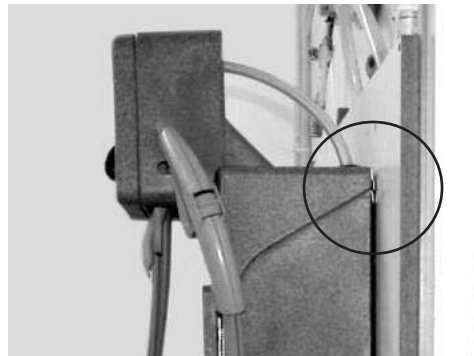

- d. Open the cabinet doors and drill the anchor screws into the wall through the holes located at the lower back of the cabinet..



KP1H Complete Mixing Station Installation

Proper installation will help you get the maximum performance and product life from your KP1H Complete system. The following instructions will guide you through the installation of a single bottle fill, bucket fill, or Dial 4 Proportioner.

Hooking up the KP1H Complete Mixing Station

1. Remove the knob by screwing out the #6 slotted head set screw at the base of the knob. (screw does need to be completely taken off to remove knob) Pull knob out to remove.



2. Using a small phillips head screw driver remove the cover by loosening two screws on the left and right side of the unit. (screws do not need to be completely taken off).



3. Thread the proper metering tip into the chemical inlet port on the side of the venturi body. (See p.14 for tip ratios.)

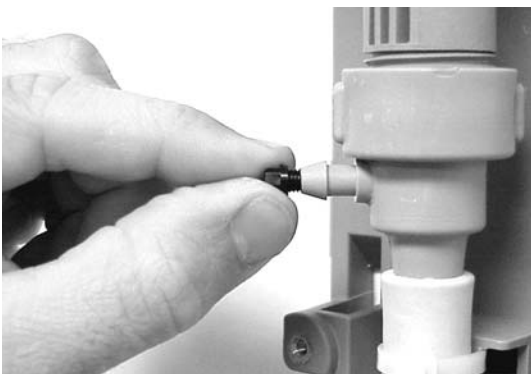

4. Remove the 3/8" supply tubes from the accessory kit. Push the supply tubes through the back. Attach the supply tubes with springs to the inlet barbs of the venturi.

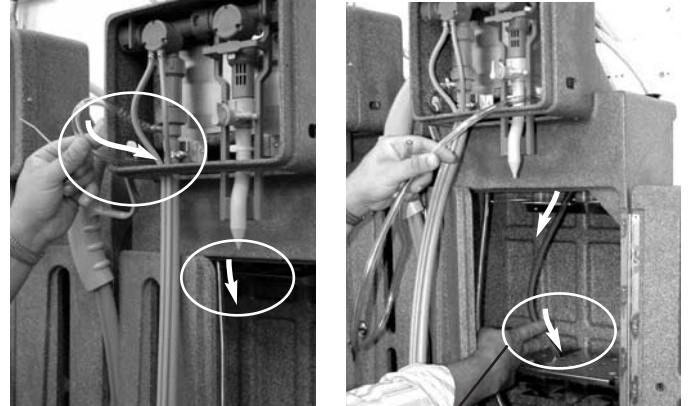

Route lower tube through oblong hole

5. For a Dial 4 Bottle Fill, attach the supply tubes to the chemical inlets, then separate the tubes with tie wraps. Allow space under the actuator arm for it to depress all the way to the wall.



6. After tubes are attached, routed, and cut to length, take the ceramic weight from the accessory kit and slide it onto the free end of the supply tube. Then install the footvalve and insert the tube.



KP1H Complete Mixing Station Installation

- Place cover back onto the proportioner and use screws to secure in place.

Note: To eliminate chemical discharge onto wall, the pre-formed fill tube can be cut for a straight discharge. Be sure to cut tube at tangent point (last bend). This may cause a slight increase in foaming.



- Add Chemical label as needed.



- Connect water source to water inlet fitting adapter. (Refer to page 5 to change water inlet location).

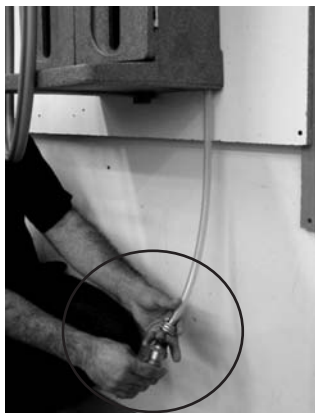

Note: Avoid extremely hot water and very high pressure.

Important note: If proportioner is connected to a janitor's sink with an atmospheric vacuum breaker, a special connection kit is required by A.S.S.E. specification 1055. Failure to use this kit, or equivalent connection methods will invalidate the A.S.S.E. and I.A.P.M.O. (UPC) certification. Specify P/N 7600187 when ordering the kit

- Installing drain port



- Reattach cover
 - Screw in the side screws.



- Attach knob with the set screw.

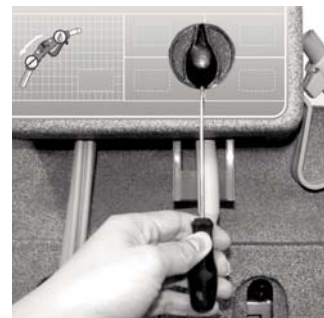

KP1H Complete Mixing Station Installation

Door Locking Procedure

1. Turn key lock up.



2. Close left door first, then close right door next over the left door



3. Push doors in and turn the key lock down.



Holstering the bucket fill gun



Changing Product Configurations

The KP1H system can be a bottle fill, bucket fill or Dial 4. To change from one product configuration to another, simply swap a few parts to create a whole new system.

CHANGE BUTTON ACTIVATION TO BOTTLE ACTIVATION

1. Remove the cover and pull out the actuator button.
2. Hook the actuator arm on the valve assembly.
3. Remove the label from the cover and replace it with the label with no button hole.
4. Place the cover back and secure with screws.

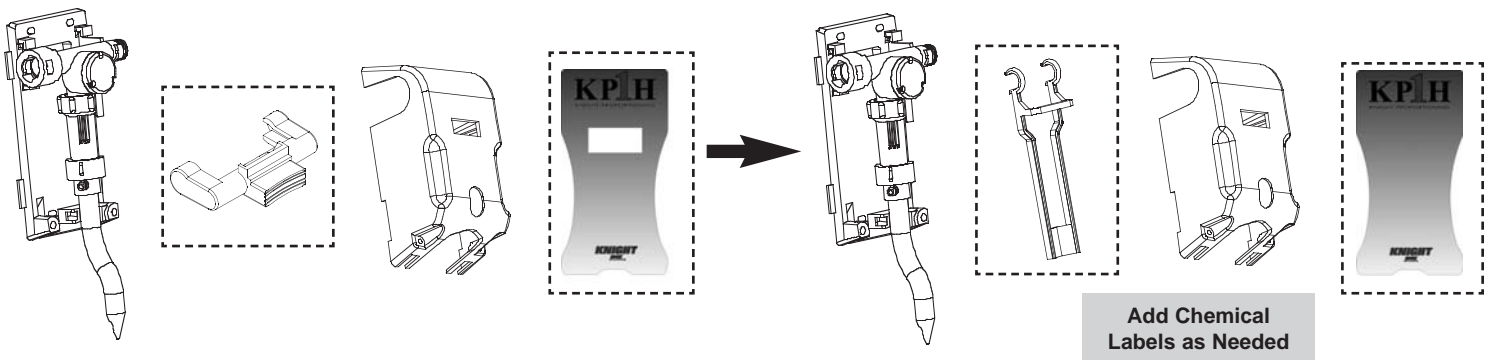

CHANGE BOTTLE FILL TO BUCKET FILL

1. Remove the cover and pull off the actuator arm.
2. Cut the plastic tie wrap around the fill tube spout, then remove the tube.
3. Remove the Lt. Gray (1GM) Flex Gap venturi body by turning it counter clockwise.
4. Replace the Lt Gray Flex Gap venturi body with a Dk. Gray (4 GPM) Flex Gap venturi body. Turn the venturi body clockwise to secure in place.
5. Slide on the bucket fill hose (with "flow" restrictor for Single Product Flex Gap towards the valve). Use tie wrap to secure in place.
6. Remove the label from the cover and slip the button actuator into the corresponding slot on the cover.
7. Place the cover back on the unit and secure it with screws.
8. Add the new label with button hole to the cover.

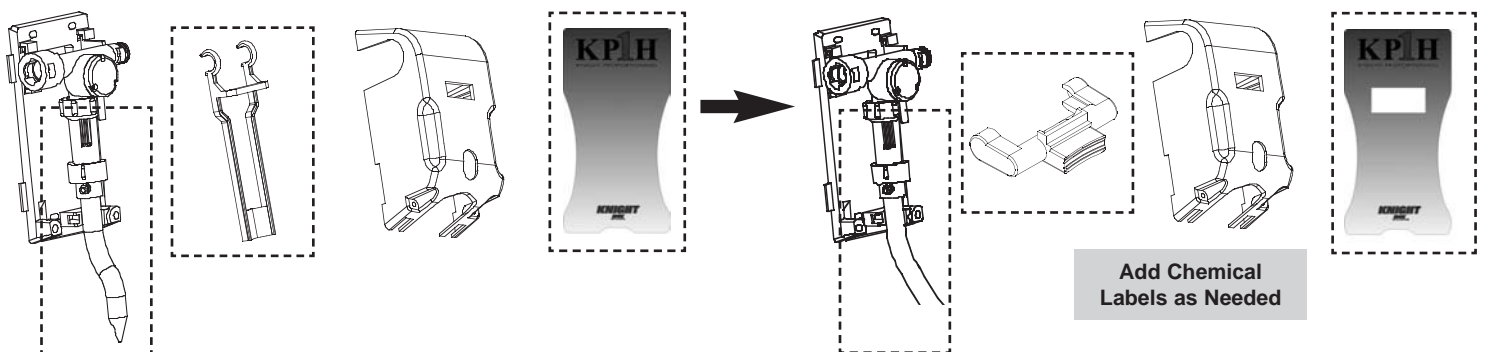

Changing Product Configurations

CHANGE SINGLE PRODUCT BOTTLE FILL TO DIAL 4 BOTTLE FILL

1. Remove the cover and pull off the actuator arm.
2. Cut the tie wrap around the fill tube spout and remove the fill tube.
3. Slide the whole valve assembly off the backing plate by pushing it to the right.
4. Remove the venturi body from the backflow assembly by twisting it counter-clockwise.
5. Take the Dial 4 Selector and attach it to the Backflow Assembly. Slide the whole valve assembly back onto the backing plate.
6. Attach the fill tube spout to the Dial 4 Selector (with the spout opening facing away from you) and use the tie wrap to secure the tube in place.
7. Hook the actuator arm back onto the proportioner. The actuator arm must be behind the chemical inlet and the fill tube spout/fill tube hose to work properly.
8. Remove the label on the cover and replace it with the Dial 4 (no button hole) label. Place the cover back on the unit and secure it with screws. (The Dial 4 knob must be in the 12 o'clock position for the cover to slide on).

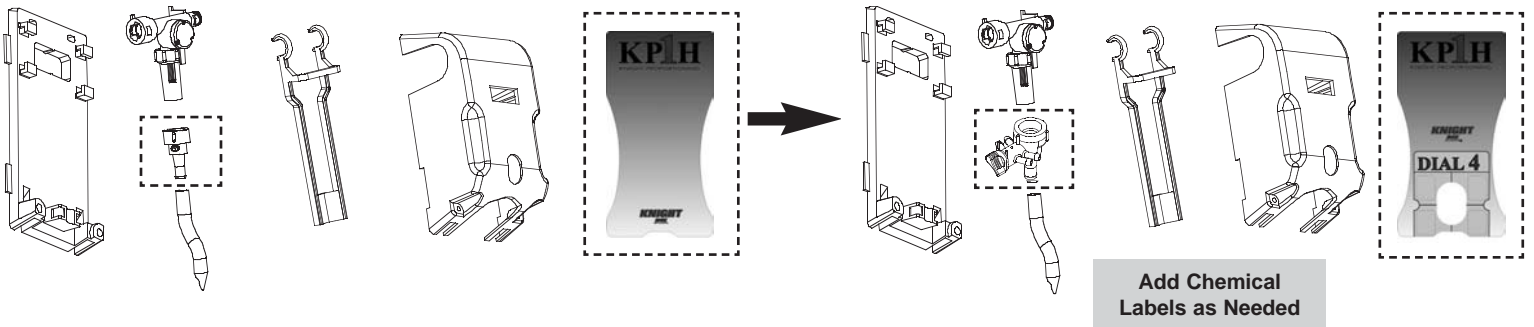

CHANGE DIAL 4 BOTTLE FILL TO DIAL 4 BUCKET FILL

1. Remove the cover and pull off the actuator arm.
2. Cut the tie wrap around the fill tube spout and remove the fill tube.
3. Slide the whole valve assembly off the backing plate by pushing it to the right.
4. Remove the 1 GPM Dial 4 Selector from the valve assembly by twisting it counter-clockwise.
5. Attach the 4 GPM Dial 4 Selector to the Backflow Assembly and slide the complete valve assembly onto the backing plate.
6. Attach the bucket fill hose to the Dial 4 Selector and use the tie wrap to secure the tube in place.
7. Remove the label from the cover and slip the button actuator into the corresponding slot on the cover.
8. Place the cover back on the unit and secure it with screws. Add a new Dial 4 label with button hole to the cover.

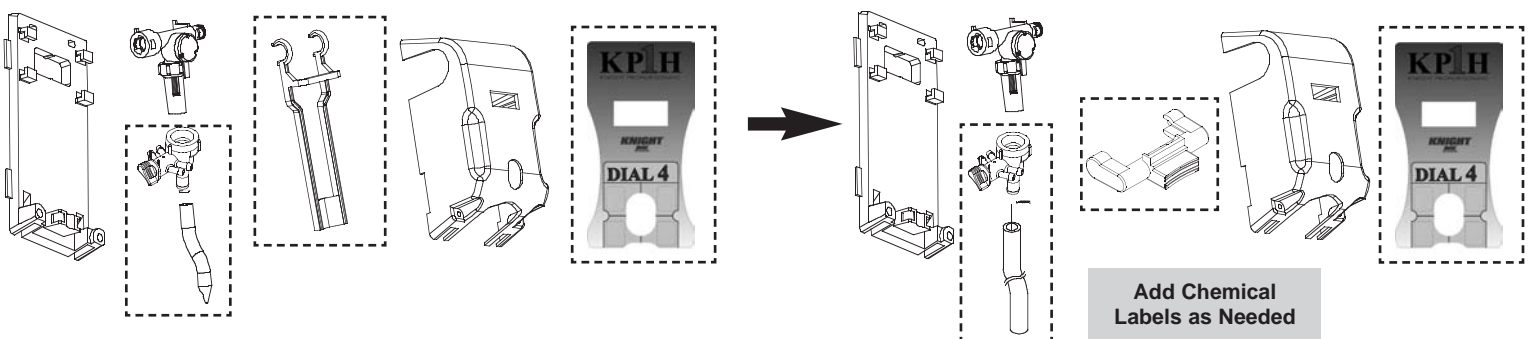

Dilution Ratio

DILUTION RATIO CHART

Mixing ratios should be used for reference only. Ratios and water flow rate will vary depending on water pressure, chemical viscosity and length of chemical lines. Ratios shown are based upon 40 PSI dynamic pressure and viscosity of water.

TIP COLOR	Aire-Gaps			
	1 GPM		3 GPM	
	OZ/GAL	RATIO	OZ/GAL	RATIO
NO INSERT				
WHITE	42.00	3.0:1	25.00	5.1:1
YELLOW	39.00	3.3:1	22.00	5.8:1
PINK	34.00	3.8:1	18.00	7.1:1
DK GREEN	26.00	4.9:1	13.00	9.8:1
BLACK	20.00	6.4:1	10.00	12.8:1
BROWN	16.00	8.0:1	7.00	18.3:1
GRAY	10.00	12.8:1	5.00	25.6:1
BLUE	8.00	16.0:1	4.00	32.0:1
RED	6.00	21.3:1	3.00	42.7:1
PEACH	5.00	25.6:1	2.00	64.0:1
LT BLUE	4.00	32.0:1	1.50	85.3:1
PURPLE	3.00	42.7:1	1.00	128.0:1
LT GREEN	2.00	64.0:1	0.75	170.7:1
ORANGE	1.00	128.0:1	0.50	256.0:1
LT BROWN	0.50	256.0:1	0.25	512.0:1

TIP COLOR	Flex-Gaps			
	1 GPM		4 GPM	
	OZ/GAL	RATIO	OZ/GAL	RATIO
NO INSERT				
WHITE	30.00	4.3:1	14.00	9.1:1
YELLOW	29.00	4.4:1	13.00	9.8:1
PINK	27.00	4.7:1	11.00	11.6:1
DK GREEN	24.00	5.3:1	9.00	14.2:1
BLACK	20.00	6.4:1	7.00	18.3:1
BROWN	14.00	9.1:1	5.00	25.6:1
GRAY	10.00	12.8:1	4.00	32.0:1
BLUE	8.00	16.0:1	3.00	42.7:1
RED	6.00	21.3:1	2.00	64.0:1
PEACH	5.00	25.6:1	1.50	85.3:1
LT BLUE	4.00	32.0:1	1.25	102.4:1
PURPLE	3.00	42.7:1	1.00	128.0:1
LT GREEN	2.00	64.0:1	0.75	170.7:1
ORANGE	1.00	128.0:1	0.50	256.0:1
LT BROWN	0.50	256.0:1	0.25	512.0:1

***Note:** Leaner Ratios Available if using Torturous Path Metering Device(T.P.M.D.) Call Knight for details.

CALIBRATING PRODUCT DILUTION RATIOS

To easily calculate the ounces per gallon for a specific product:

1. Fill a graduated cylinder or bottle that has measuring marks for ounces with the chemical product to be tested. Record the product name on the cylinder or bottle.
2. Activate the proportioner until the chemical line is primed up to the metering tip.
3. Record how many ounces of chemical product are in the cylinder or bottle.
4. Activate the proportioner again and fill a one gallon container with the water/product mixture.
5. Read the cylinder or bottle and note how many ounces of chemical product were used.
6. Now you know the amount of chemical used per gallon of mixture for this product. Repeat steps for the other valves and products.

DIAL 4 SELECTOR POSITIONING

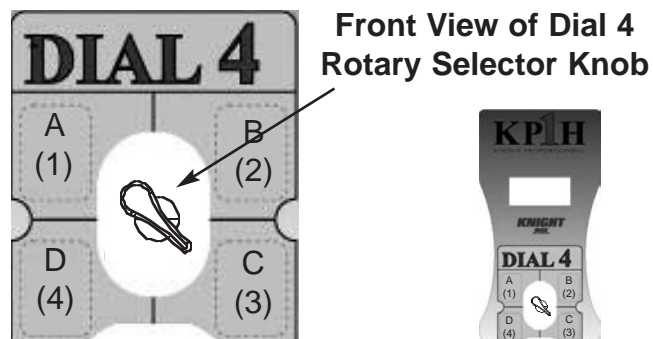
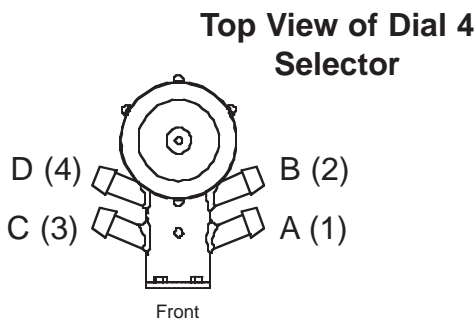

Changing Flow Rates

FLEX GAPS

The Flex Gap venturi body is molded for either a 1 or 4 GPM flow rate. To change the flow rate:

LIGHT GRAY = 1GPM
DARK GRAY = 4GPM

1. Remove the Flex Gap venturi body by turning it counter clockwise.
2. Install the appropriate venturi body.

(Note: For Dial 4 s remove the valve assembly from the backing plate first, then remove the Dial 4 selector by turning it counter clockwise. Replace with desired GPM model.)

AIRE-GAPS

For Aire-Gap venturi systems, the flow rate is controlled by a nozzle, deflector plate, and venturi tube. These internal parts are color coded to identify their GPM rating:

Blue = 1 GPM
Black = 3 GPM

To change these parts:

1. Disconnect tubing from venturi body.
2. Remove Aire Gap assembly from water valve.
3. Remove existing nozzle, deflector plate, and venturi tube by disassembling the Aire Gap. (See figure)
4. Reassemble the Aire Gap using new nozzle, deflector plate, and venturi tube (for the desired flow rate). To avoid leakage, install the rubber washer with the 3 "ears" facing upwards. Hand-tighten the venturi body to the Aire Gap body.
5. Thread Aire Gap assembly back and hand-tighten in place.

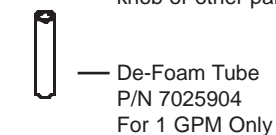
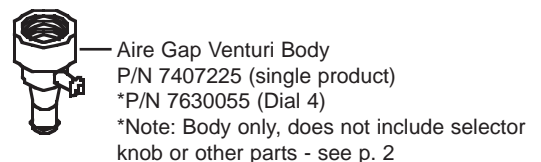
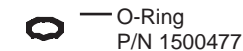
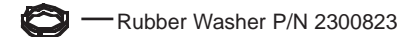
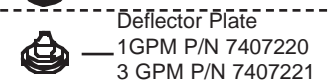
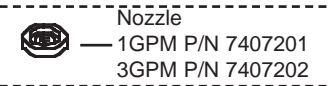
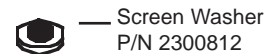

AIRE GAP ASSEMBLY

Pressure Regulation

The optimum water pressure to create maximum vacuum is 30 – 60 PSI. **Use of the Brass Pressure Regulator (P/N 7407117) on the input side of the KP1H Complete is Mandatory for safe operation of this System.** The regulator will prevent the flow pressure from exceeding 45 PSI.

Knight recommends a fixed pressure regulator that threads into a standard garden hose adapter,

Knight #7407117
(as shown)



1. Disconnect water line and attach pressure regulator to water inlet adapter.



2. Reconnect water line to adapter on regulator.

TROUBLESHOOTING

1. Dispenser will not draw chemical:
 - A. Check metering tip for obstruction.
 - B. Check water pressure for 30 – 60 PSI.
 - C. Check or change footvalve.
2. Dispenser leaks at joints:
 - A. Ensure that both "O"-rings are in place on bayonet end of valve body.
 - B. Inspect "O"-rings for damage and for lubrication.
3. Mixed chemical concentration is too weak:
 - A. Check water pressure for a minimum of 25 PSI of flow pressure.
 - B. Change metering tip to a higher dilution ratio.
4. Valve activates when cover is pressed:
 - A. Make sure backing plate has mounting screw in top and bottom corners.
5. Supply line loses chemical prime:
 - A. Check or change foot valve.
6. Water leaks at cap on valve assembly:
 - A. Loose or "stripped" screw. Replace screw.
 - B. Excessive water pressure. Use Regulator.
7. Button or bottle actuator will not activate valve:
 - A. The cover is loose or damaged, tighten screws or replace the cover,
 - B. Adjust calibration screw until full flow is achieved.
8. Dial 4 will not draw chemical:
 - A. Check condition of o-rings on dial selector knob
 - B. Ensure Dial "Clicks" to selected product.
9. Low water flow:
 - A. Check that cover is firmly attached.
 - B. Check for sediment in screen washer or valve body.
 - C. Check water pressure.

Maintenance

Proper product maintenance can improve the performance and extend the product life of your KP1H system. Periodically check the following:

- Metering tips for proper dilution rate.
- Screen on foot valve to make sure supply line is staying primed.
- Button activation for proper operation. If activation is not correct, check cover; if the cover is loose, tighten the screws on the cover.

Warranty

Knight controls and pump systems are warranted against defects in material and workmanship for a period of ONE YEAR. All Electronic Control Boards have a TWO YEAR warranty. Warranty applies only to the replacement or repair of such parts when returned to the factory with a KRA number, freight prepaid and found to be defective upon factory inspection. Rubber and synthetic rubber parts such as "O" rings, diaphragms, squeeze tubing and gaskets are considered expendable and are not covered under warranty. Warranty does not cover liability resulting from performance of this equipment nor the labor to replace this equipment. Product abuse or misuse voids warranty.

Footnote

The information and specifications included in this publication were in effect at the time of approval for printing. Knight, LLC reserves the right, however, to discontinue or change specifications or design at any time without notice and without incurring any obligation whatsoever.

Certificate of Compliance

Certificate: 1376245	Master Contract: 202706
Project: 1777669	Date Issued: 2006/04/28
Issued to: Knight (Canada) Limited 6 - 2880 Argentia Rd Mississauga, Ontario L5N 7X8 Canada Attention: Wayne Anningson	

The products listed below are eligible to bear the CSA Mark shown

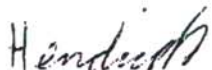

Issued by: W. Hendricks, B. Eng.

Authorized by: Nick Alfano, Operations
Manager

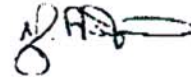

PRODUCTS

CLASS 6811 01 - PLUMBING FITTINGS AND ACCESSORIES - Fittings

- Air Gap for Chemical Dispenser: Air-Gap, Flex-Gap.
- Chemical Dispenser Systems with Air-Gap or Flex-Gap: 7114112XXXX, 71163XX, 7116XXX, 7117XXX, 7630061, 7630062, 7630063, 7630064, 7630065, 7630066, 7630067, 7630068, 7630069, 7630070, 7630071, 7630072, 76301XX, 76301XX-XX, 763015X, 763015X-XX.

APPLICABLE REQUIREMENTS

CSA Standard B125-01 - Plumbing Fittings

CSA Standard B64-01 - Backflow Preventers and Vacuum Breakers

Flex-Gap Cleaning and Test Procedures

FLEX-GAP ANNUAL CLEANING AND TEST PROCEDURES FOR UNITS INSTALLED IN CANADA

Each year, your chemical dispenser must be cleaned and its backflow prevention performance verified. As this device is an end-of-line device (versus an in-line device) and evidence of effective backflow prevention is determined visually, a two-minute pressure test is not necessary.

If the Flex-Gap device cannot readily be seen during the test procedure, the housing of the chemical dispensing unit must be removed during testing. Apply the appropriate test procedure below as applicable for your chemical dispensing unit.

4 GPM VENTURIS

1. Fill discharge hose with water by opening the valve.
2. When water begins to exit the discharge hose turn off the water and raise the end of the hose above the Flex-Gap.
3. Observe that water is exiting the Flex-Gap.
4. If the water is exiting the Flex-Gap it has passed the test.
5. If the water is not exiting from the Flex-Gap, replace the Flex-Gap sleeve as per the instruction manual and re-test.
6. If the water is not exiting from the Flex-Gap after replacing the sleeve and re-testing, replace the complete Flex-Gap assembly and re-test.
7. If the water is not exiting from the Flex-Gap after replacing the Flex-Gap assembly, disconnect the water supply and replace the complete unit.

1 GPM VENTURIS

1. Remove the Fill Tube Spout and replace with a 4-foot length of 1/2" ID hose.
2. Fill the discharge hose with water by opening the valve.
3. When water begins to exit the discharge hose, turn off the water and raise the end of the hose above the Flex-Gap.
4. Observe that water is exiting the Flex-Gap.
5. If the water is exiting the Flex-Gap, it has passed the test.
6. If the water is not exiting from the Flex-Gap, replace the Flex-Gap sleeve and re-test.
7. If the water is not exiting from the Flex-Gap after replacing the sleeve and re-testing, replace the complete Flex-Gap assembly and re-test.
8. If the water is not exiting from the Flex-Gap after replacing the Flex-Gap assembly, disconnect the water supply and replace the complete unit.

KNIGHT

Knight Headquarters
Toll Free (800)854-3764
Tel (949) 595-4800
Fax (949)595-4801
www.knightequip.com

Knight Canada
Tel (905)542-2333
Fax (905)542-1536

Knight Europe
Tel +44(1293)615.570
Fax +44(1293)615.585

Knight Australia
Tel +61(2)9725.2588
Fax +61(2)9725.2025

Knight N. Asia
Tel +82(2)3481.6683
Fax +82(2)3482.5742

Knight S. Asia
Tel +65.9170.0984
Fax +65.6489.6723