

---

# **KNIGHT<sup>®</sup>**

## **IDEX**

**FLUID & METERING**

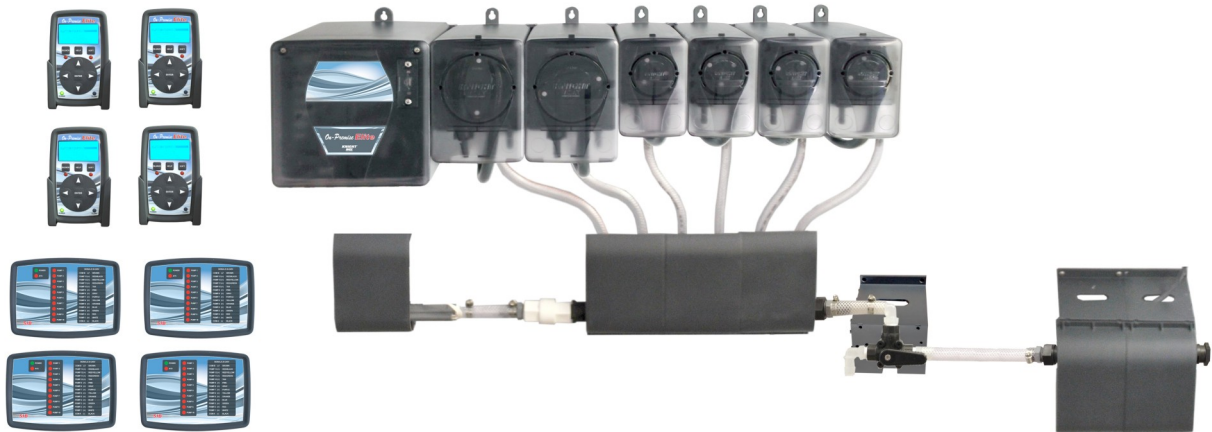

# **On-Premise Elite Installation Manual**

---

## TABLE OF CONTENTS

Specifications .....	3
Operation.....	4
Pre-Installation.....	5
Installation .....	5
Split Common Wiring.....	6
Multi Washer Diagrams .....	9
Single Washer Diagrams .....	15
Squeeze Tube Replacement .....	22
System Alarms .....	24
Troubleshooting.....	25
Conformity Documentation .....	27
Warranty Information .....	28
Knight Locations .....	28

### ***Equipment Ratings***

This includes equipment supply, description of I/O connections, duty cycle and operating environmental conditions.

1. Pollution degree 2
2. Installation category 2
3. Altitude 2000 m
4. Humidity 50% to 80%
5. Power supply 100 - 240 VAC, 2.0 A, 50/60 Hz
6. Indoor use only
7. Temperature 5°C to 40°C
8. Mains supply voltage fluctuations are not to exceed 10 percent of the nominal supply voltage

### ***Electrical Ratings***

Chemical dispensing pumps, Models OP-Elite, permanently connected, rated 100 - 240 VAC, 2.0 A, 50/60 Hz



**CAUTION: Wear protective clothing and eyewear when dispensing chemicals or other materials. Observe safety handling instructions (MSDS) of chemical mfrs.**



**CAUTION: To avoid severe or fatal shock, always disconnect main power when servicing the unit.**



**CAUTION: When installing any equipment, ensure that all national and local safety, electrical, and plumbing codes are met.**

---

## SPECIFICATIONS

Max Number of Washers .....	4
Max Number of Chemicals for Single washer .....	10
Max Number of Chemicals for Multi-washer .....	8
Voltage .....	100—240 VAC
Frequency.....	50 or 60 Hz
Current.....	2.0A
Water Pressure.....	30 - 40 PSI / 2 - 2.75 bar
Water Temperature.....	32 - 120°F / 0 - 50°C
Max Distance to Washer.....	100 feet / 30.5M
Peristaltic Pump Duty Cycle (minutes).....	2 on / 15 off
Humidity (max).....	50 to 80%
Working Temperature .....	41 - 104°F / 5 - 40°C
Storage Temperature.....	-40 - 185°F / -40 - 85°C

## IMPORTANT NOTE

Do not use starch with a flow meter! This will cause the flow meter to clog up and stop working.

## SAFETY SYMBOL EXPLANATIONS

Listed below are explanations of the safety symbols that appear either on the unit, in the instruction manual, or both. Please familiarize yourself with the meaning of each symbol.



**GENERAL CAUTION:** This symbol indicates a general safety caution.



**SHOCK HAZARD:** This symbol indicates that hazardous voltages are inside the enclosure.



**READ MANUAL:** This symbol indicates to read the manual for important instructions and procedures related to safety.

---

## OPERATION

**□ NORMAL MODE:** The system is capable of 100 user selectable formulas with each formula having unique volumes and delay times for each pump. Signals from the washer trigger the pumps, then the OP-Elite takes control to count down delay times and run times with up to 4 individual “levels” (explained below) for each pump. The supervisor of the facility, or the machine operator, will select the formula using ◀/▶ buttons to choose the appropriate wash formula when the formula menu line is highlighted on the run time screen.

Programming “levels” allows a pump to inject different amounts of chemical for multiple signals to the same pump during a formula. For example, pump 1 could inject 8 ounces of chemical on its first signal, then later inject 12 ounces of chemical on its second signal. Four levels are available for any pump on any formula, except for the load count pump. **ONLY 1 LEVEL CAN BE PROGRAMMED FOR THE LOAD COUNT PUMP** (and any other pump that may be signaled simultaneously with the load count pump’s signal). The level feature can also be used to “skip over” an injection. Simply do not program any volume or delay time for that level.

When a formula begins (after power is turned on or the “Load Count” pump has been triggered from the previous formula) the first signal to a pump will activate level 1. The signal has to be present for at least qualifying time to be recognized. The second signal to the pump during the formula will activate level 2. The third signal to the pump during the formula will activate level 3. The load count pump signal must be received to reset levels in preparation for the next formula.

**□ DRAIN MODE:** This mode is similar to normal operation but requires only one signal source from the washer and works by counting the number of drains during a wash cycle. When programming the dispenser for Drain Mode use, each chemical pump is assigned a specific drain occurrence (“drain count”) to inject product on. This feature only affects how the pumps are triggered – all other functions such as pump volumes, delay times, and flush mode, will still operate in their normal fashion.

During a wash formula, each drain signal is counted and the pumps inject chemical according to the drain number they are assigned. Drain mode is similar to normal operation, in that the pumps are programmed with volumes (and delay times if necessary) and the flush mode works the same way it does in normal operation.

The “multiple level” feature works slightly different in drain mode, because of the way drain mode counts the number of signals to pump #1 input. If a second injection level is required, it should be programmed to inject on a later drain number (occurrence) than the first level for that pump.

- Using signal lockout is not recommended for drain mode operation.
- During a wash cycle, when pumps are idle, the display will show the formula name on the bottom line of the display and the current drain count on the top line. When a normal wash cycle has ended, the load count will be displayed.
- Cycling power will reset the drain count if an incomplete load has been run.
- All pump dosing must occur prior to the Last Drain Signal. The Last Drain Signal indicates to the dispenser to end the cycle for the active formula. For example, if you have a last drain count of 5. You can assign pumps to drain counts 1 through 4, drain count number 5 will act like a load count pump to end the cycle.
- The Drain Signal State configures the dispenser to increment the drain count based on signal polarity. If the Drain Signal state is set to Normal, an Energized Drain Signal will increment the drain count. If the Drain Signal State is set to Inverted, a De-energized Drain Signal will increment the drain count.

**□ RELAY MODE** (not for use with multi-washer): This type of operation is typically used with a single microprocessor controlled washer. When set to relay mode, the system will run its pumps as long as their respective signals are present. To accomplish this, the system “by-passes” its volume and delay time capabilities for the chemical pumps; however, flush mode is still available for optional use.

**□ SOIL MODE:** This operation allows three different soil classifications (light, medium, heavy) and the option of selecting bleach or softener. When a wash cycle is ended, the system automatically resets itself to default settings. For example: The medium soil classification is automatically selected. The operator can choose light or heavy based on the next soil load. The bleach and softener pumps are also reset to their default settings (enable or disable, based on your specific programming preference). The bleach and softener pumps can also be overridden as necessary for the next wash cycle.

- Formula 1 = Heavy Soil
- Formula 2 = Medium Soil
- Formula 3 = Light Soil

---

## PRE-INSTALLATION

Before the equipment is installed, you should survey the installation site thoroughly. At the very least, your survey should include the following:

- Check to make sure that all functions of the washmachine are operating properly. Including; card reader or timer, water solenoids, flush down valves, water level switch, machine motor, and drain valve.
- Check the proposed location for a 100-240 VAC power source.
- Check voltage of all supply signals that will be used from the washmachine. Measure voltage between supply signal and signal common with a voltmeter. DO NOT check signal voltage between supply signal and case (earth) ground.
- Measure the distance from chemical supply containers to pump housing, and from pump housing to injection point inside washmachine.

## INSTALLATION

### (1) Disconnect all power to washer.

- (2) Mount pump cabinet in a convenient location no higher than 8' above, and within 10' horizontally, of supply containers. This is usually near the washer, however dispenser can be mounted as a remote pumping system.
- (3) Using the provided mounting bracket, mount the **Remote Control** to the front of the washer where operators can easily access it. Secure the bracket to washer using provided mounting screws or Dual-Lock fastening strips (be sure to first clean the mounting surface as the adhesive will not stick to a dirty surface).
- (4) Connect 100 - 240 VAC power source to main power connection in pump cabinet. Use suitable conduit for electrical wiring (per applicable wiring codes). A suitable ground conductor should be connected to the ground terminal in accordance with local electrical codes. The user/installer should provide a disconnect switch or circuit breaker close to the equipment and should be marked that it is for this equipment.

NOTE: Low voltage Plug & Play cables do not require conduit.

- (5) Install and wire the **Signal Interface Module (SIB)** per notes on the following pages.
- (6) For each pump, cut the suction tube to length and insert one end into the appropriate supply container using PVC pipe as a support. Insert other end of suction tube into the left (input) side of the pump's squeeze tube.
- (7) For each pump, cut the discharge tube to length and insert one end into the right (output) side of the pump's squeeze tube. Form an anti-siphon loop (pointing "down") with the other end of discharge tube and insert into the supply pocket of the machine.
- (8) The system is now ready to be powered up and programmed.

### ***The Signal Interface Module (SIB):***

The SIB receives supply signals from the washer, then communicates with the dispenser to run the pumps. For External SIBs, the low voltage cable allows a quick, clean connection from the module to the pump system without requiring conduit. For an Internal SIB, all Washer signals can be connected inside the Main Enclosure.

- (1) For External SIBs, mount the module using the provided Dual Lock adhesive strip. The module can be mounted inside the washer's controls, along side the washer's controls, or to the bottom of the pump cabinet. Internal SIBs are pre-installed at the factory
- (2) Connect the low voltage cable from the module to the OP-ELITE REMOTE terminal located inside the main enclosure to the MAIN terminal on the SIB. If this is a Multi-Washer System, chain each washer's SIB from the Main terminal of a previously connected SIB in a daisy chain fashion. SIBs must be connected in a linear progression (see wiring diagram).
- (3) Connect the supply signals to the SIB per wire colors on the SIB label. If using Drain Mode, only one signal is required (Signal #1).
- (4) If you have one signal common (typical) connect the common to "COM A" on the SIB. If you have two signal commons, you will need to configure the SIB before connecting the common wires! See the details on the following page.

## SPLIT COMMON SIGNAL WIRING

For most applications, the SIB will typically have only one signal common connection, as most washers have trigger signals that utilize the same common (shared neutral) for all signals. However, for special applications, the SIB can be configured to accept isolated common connections for various combinations of pumps. This is also referred to as “splitting commons” (isolated neutrals) in reference to the washer trigger signals.

### OP Elite standard models

- Locate the three resistors marked R15, R16, and R17, on the SIB circuit board (each resistor has a single black band to identify).
- Cut and remove the resistor that will “split” the commons between the desired pumps (remove only one resistor).

CUT RESISTOR	TO USE COM A FOR PUMPS	AND COM B FOR PUMPS
R15	1 - 2	3 - 10
R16	1 - 3	4 - 10
R17	1 - 5	6 - 10

### European models

The choice of shared commons or isolated commons is determined by switch settings within the SIB. Each trigger signal input has its own slide switch to choose between shared common or isolated common.

- SHARED NEUTRAL:** All pump signal inputs that are set for this option will have their respective neutral connections (on the PCB) joined together so that the signal common wire from the washer only needs to be connected to the any one of the neutral terminals.
- ISOLATED NEUTRAL:** All pump signal inputs that are set for this option will have isolated neutrals. Each of these particular pumps must then have their own separate neutral connection apart from the other pumps in the system.

### OP Elite standard SIB

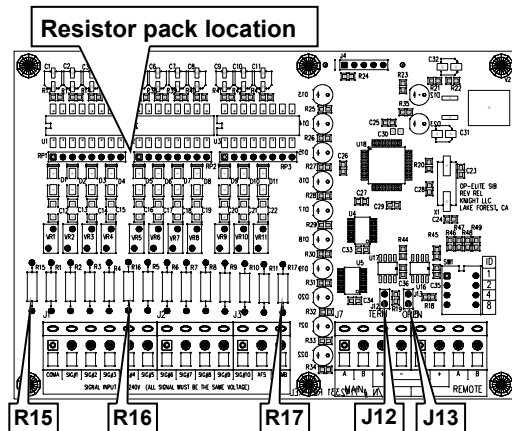

### European model SIB

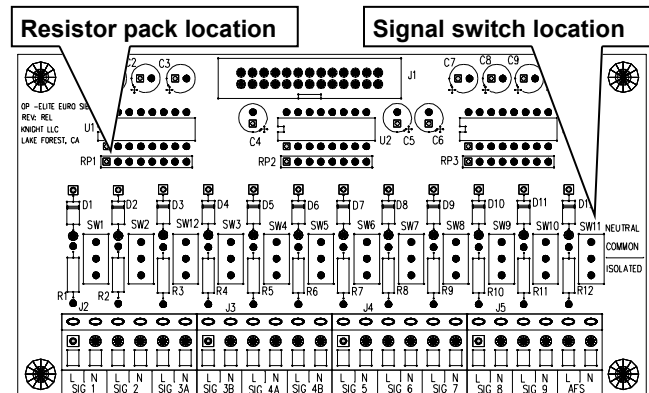

## LOW VOLTAGE SIGNAL FILTER

The SIB has low voltage signal filtering capability that can help prevent unwanted injections caused by low voltage stray signals or “bleed” voltages. The signal filter is controlled by resistor packs inside the SIB. The resistor packs are marked RP1, RP2, and RP3.

- When the resistor packs are in place (normal) the signal input range is 100 – 240 volts.
- When the resistor packs are removed, the signal input range is 24 – 240 volts.

RESISTOR PACK	100–240V SIGNAL RANGE	24–240V SIGNAL RANGE
RP1	IN	OUT
RP2	IN	OUT
RP3	IN	OUT

### How to remove the resistor packs (external SIB)

- Take out all screws from the bottom of the SIB to open the module.
- Carefully remove the resistor packs marked RP1, RP2, and RP3.
- Close the module and replace screws when finished.

## SIB DAISY-CHAIN WIRING

When Wiring a Multi-Washer system, Terminal J4 location, labeled as Remote, on the OP-Elite Connection Board must be connected to J7, labeled as MAIN, on each Standard SIB in a bus like fashion. The SIB closest, for this example we will refer to it as SIB A, will need to be connected to the Dispenser with a single cable. The next SIB, referred as SIB B, will need to be connected to SIB A with a single cable. The third SIB connected, referred to as SIB C, will need to be connected with a single cable to SIB B. The last SIB, referred to as SIB D, will need to be connected to SIB C with a signal Cable. So from the dispenser to SIB D will be a single long chain with SIB A, B and C between.

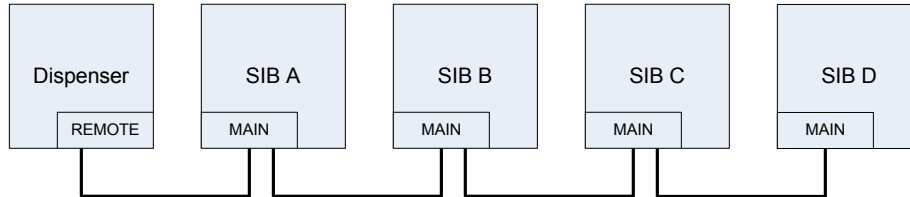

The jumpers and addresses on each SIBs will also need to be set in order for the Multi-Washer system to operate properly. The last SIB, and only the last SIB, on the Chain must be set to terminate the chain. By default, all SIBs that are packaged are currently set to Terminate the chain. In the example above, SIBs A, B and C will need to be changed from their default TERM state to an OPEN state. Changing a SIB from the TERM state to an OPEN state can be done by moving the Jumper on J12 to J13. Leave the Jumper on J12 if the SIB must be in the TERM state.

Lastly, every SIB must be set to a unique yet valid address. There are for valid addresses, 0, 1, 2 and 3. Set washer 1 as SIB address 0, washer 2 as SIB address 1, washer 3 and SIB address 2 and washer 4 as SIB address 3. SIB Addresses are set with SW1.

- Address 0 is 1, 2 3 and 4 to OFF
- Address 1 is 2, 3 and 4 to OFF; 1 to ON
- Address 2 is 1, 3 and 4 to OFF; 2 to ON
- Address 3 is 3 and 4 to OFF; 1 and 2 to ON

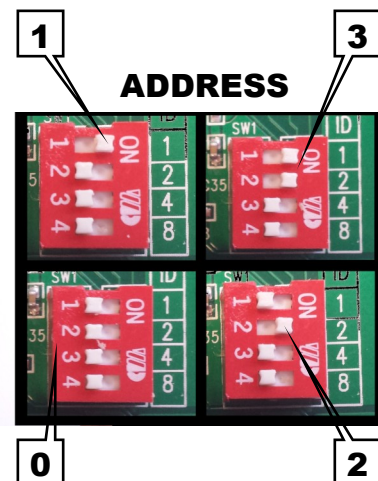
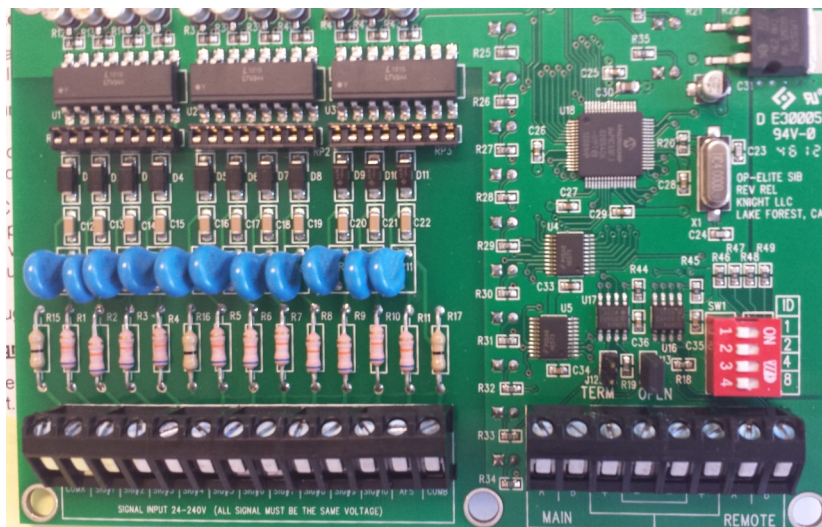

# SIB DAISY CHAIN WIRING

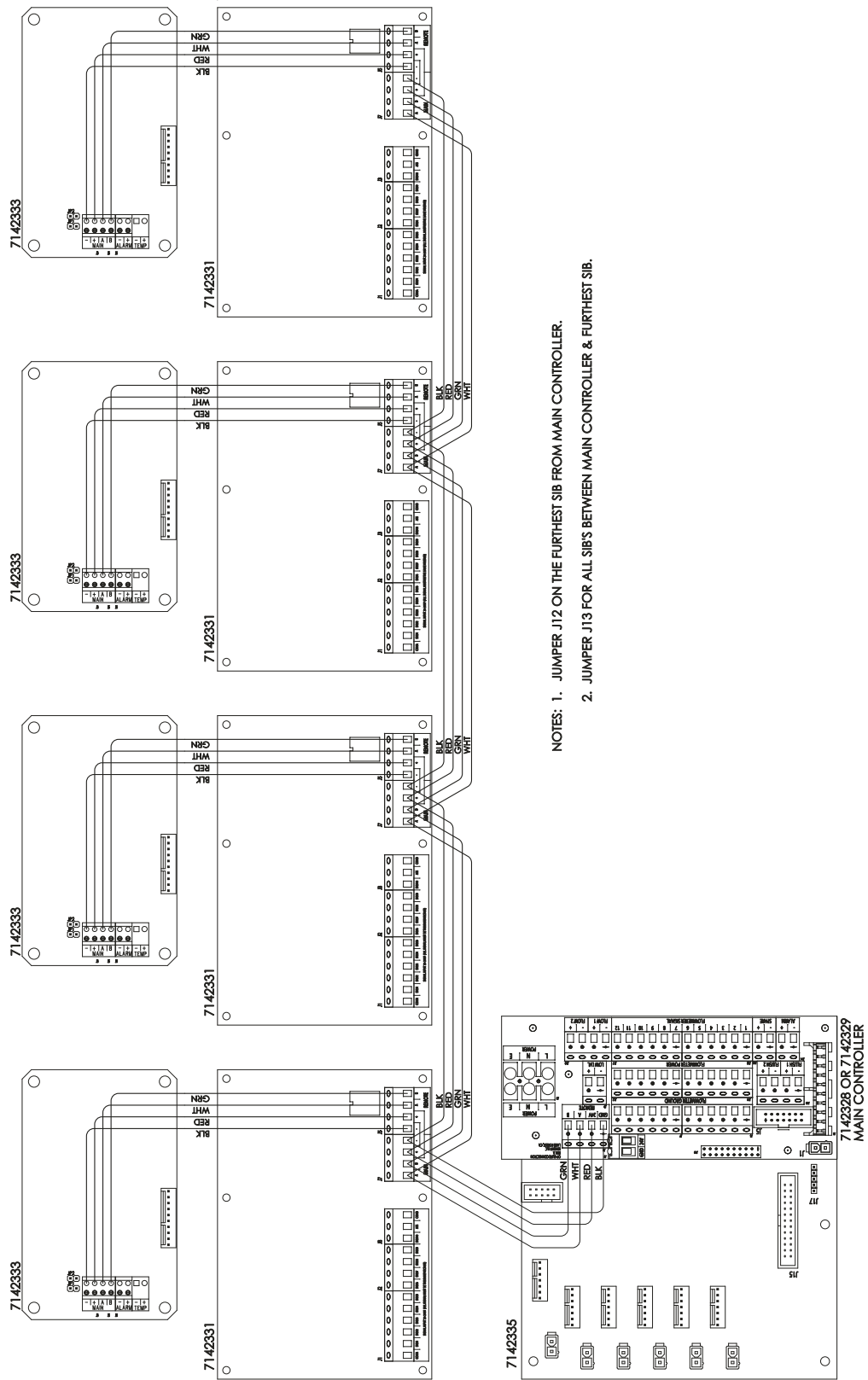

- NOTES: 1. JUMPER J12 ON THE FURTHEST SIB FROM MAIN CONTROLLER.  
 2. JUMPER J13 FOR ALL SIB'S BETWEEN MAIN CONTROLLER & FURTHEST SIB.



# MULTI WASHER MAIN HOUSING

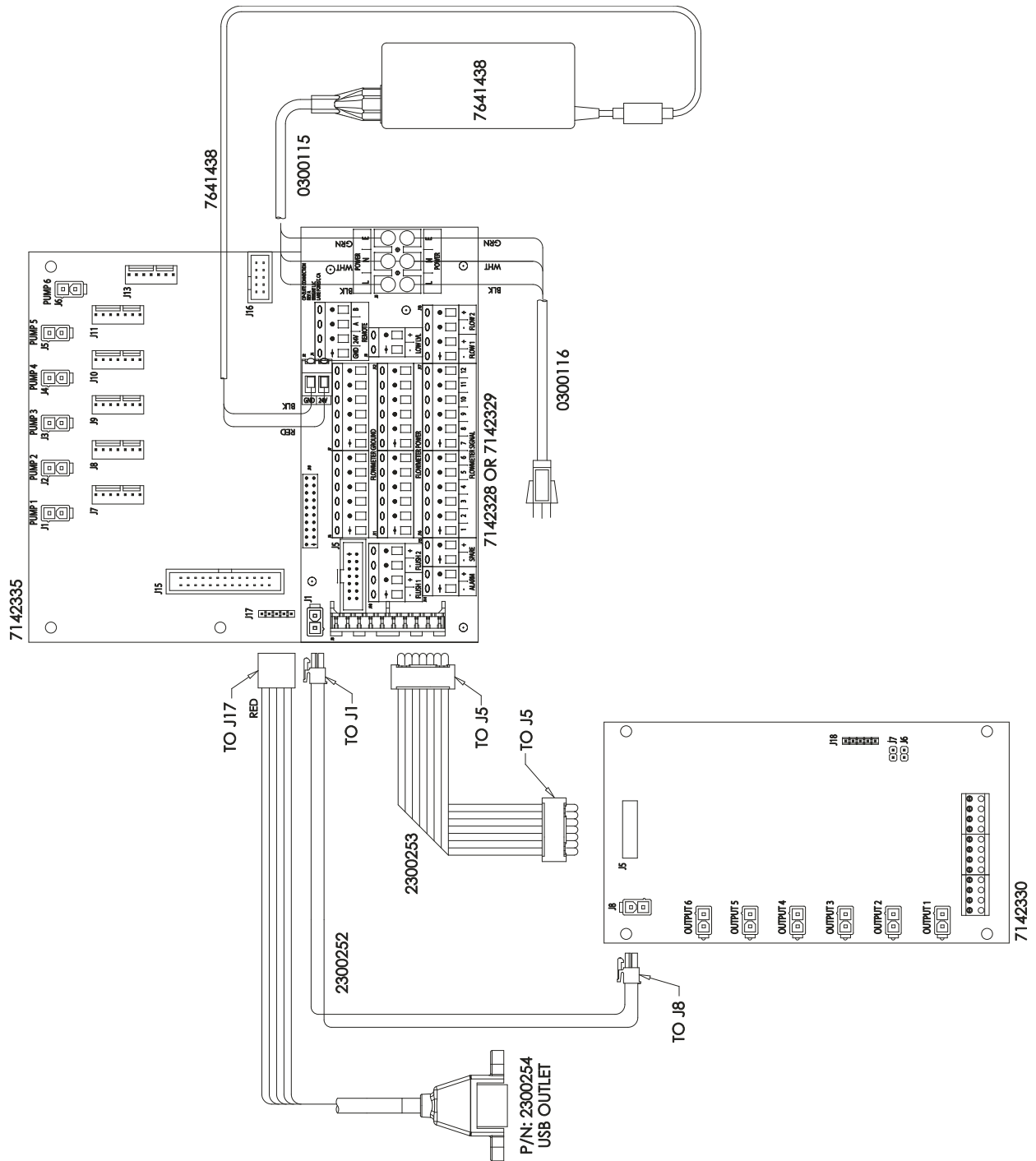

# MULTI WASHER PUMP CONNECTION

TABLE 1

PUMP MOTOR WIRE HARNESS		
PUMPS	#1 THRU #4	#5 THRU #8
PART NUMBER	2300251	2300250

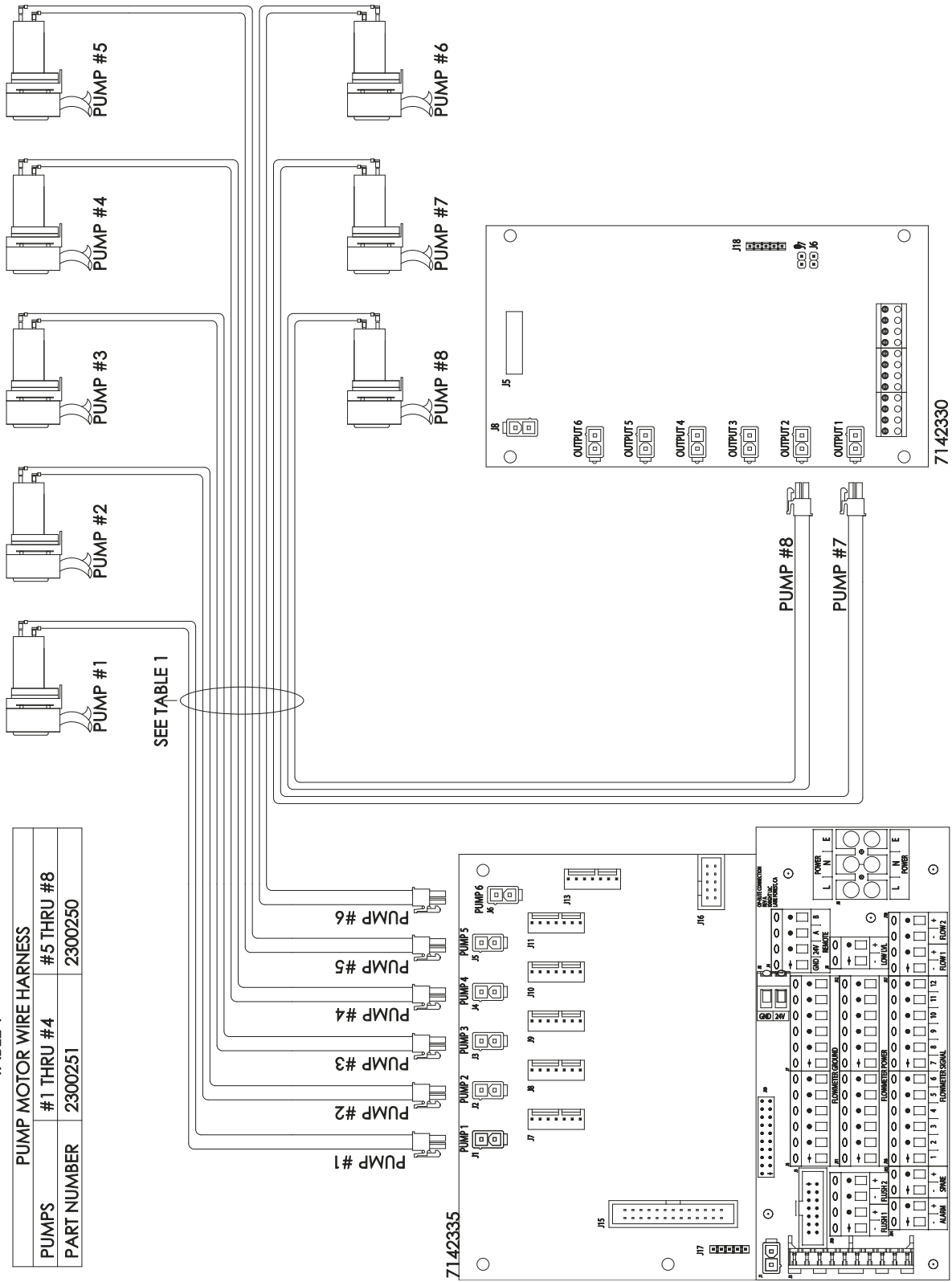

# MULTI WASHER DIVERTER VALVES / FLUSH SOLENOID

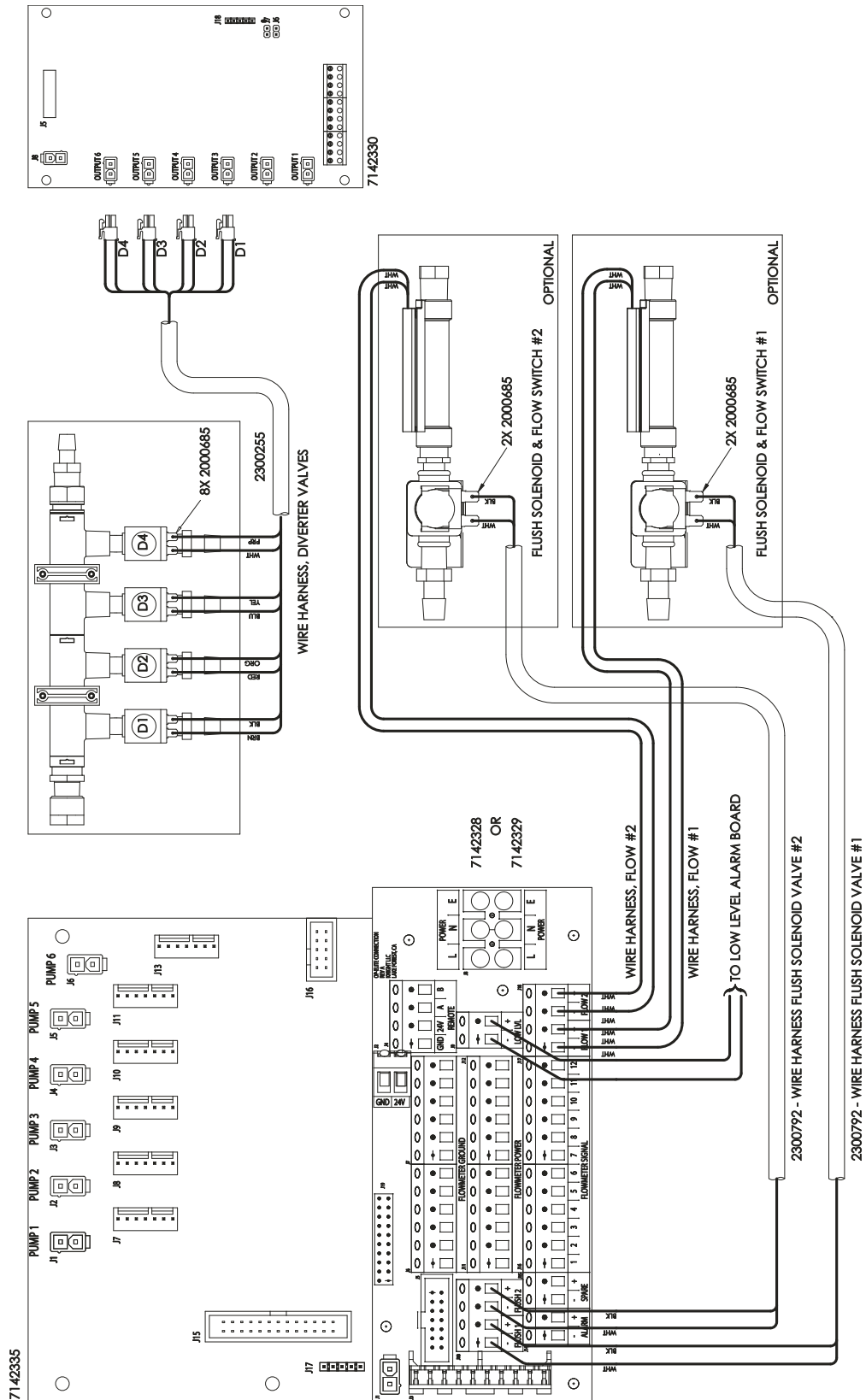

# MULTI WASHER FLOW METERS

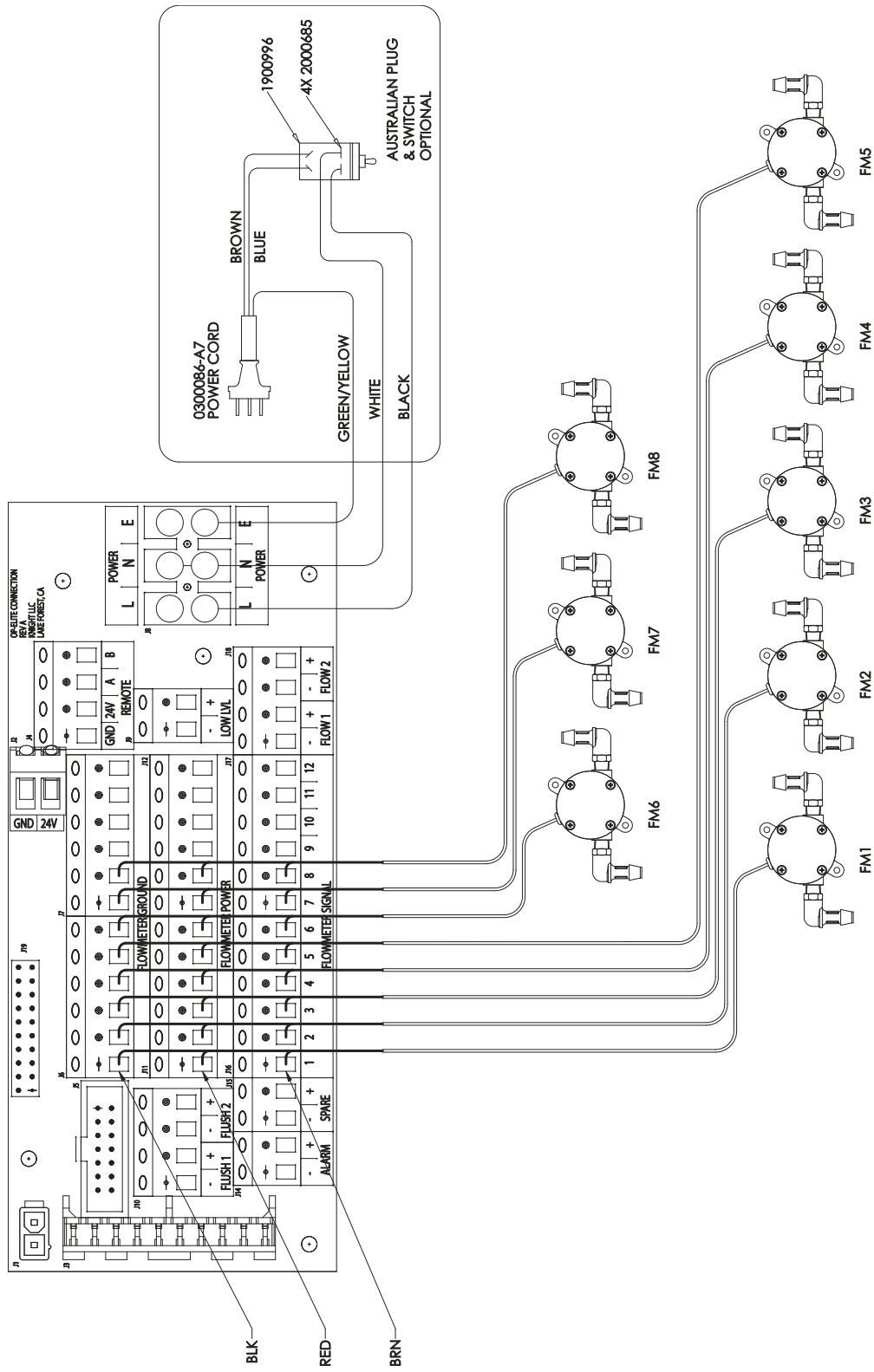

**FLOW METERS**  
OPTIONAL

**Warning: Do not use starch with a flow meter! This will cause the flow meter to clog up and stop working.**

# MULTI WASHER PUMP CONNECTION

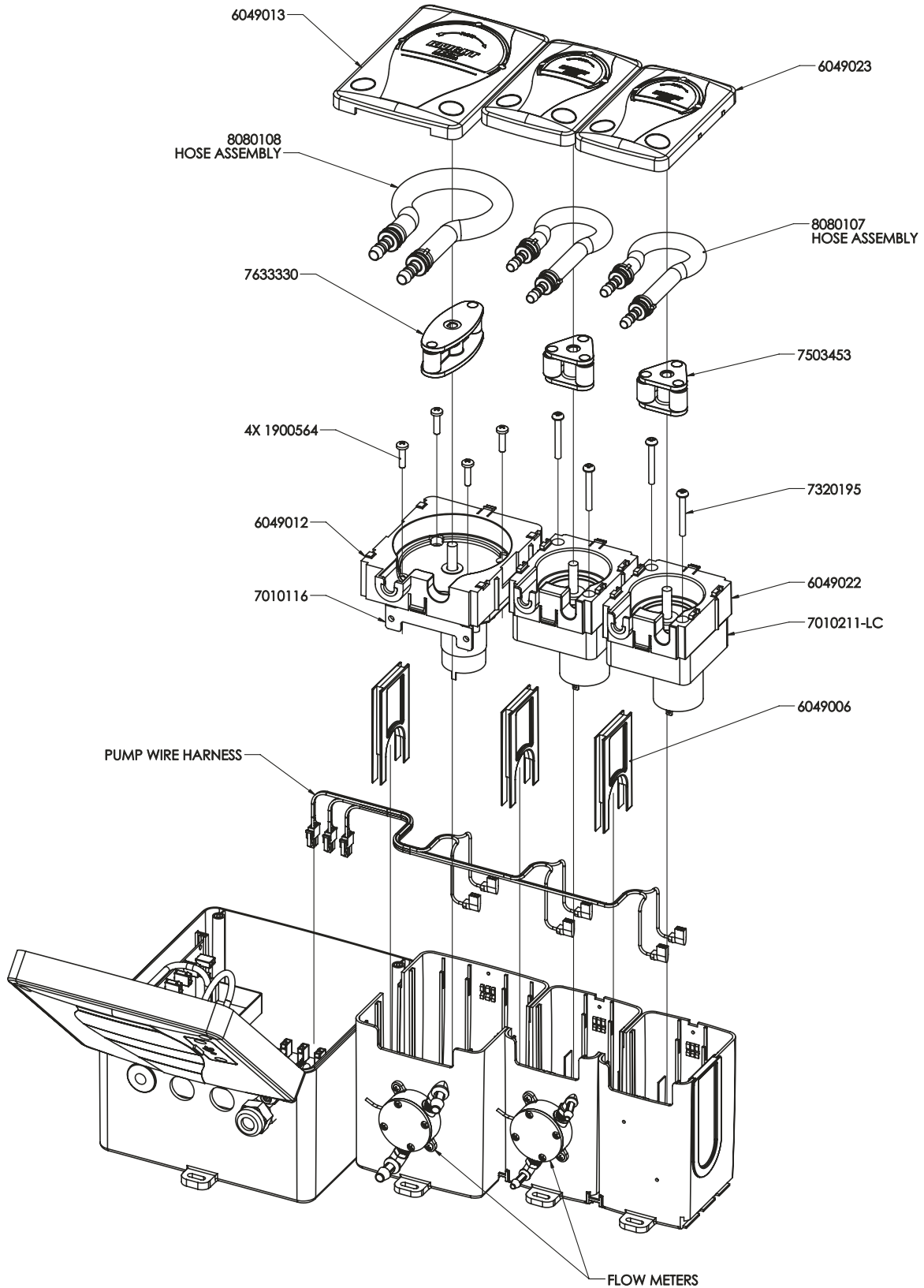

---

## MULTI WASHER PRIMING BOARD & EUROPEAN SIB

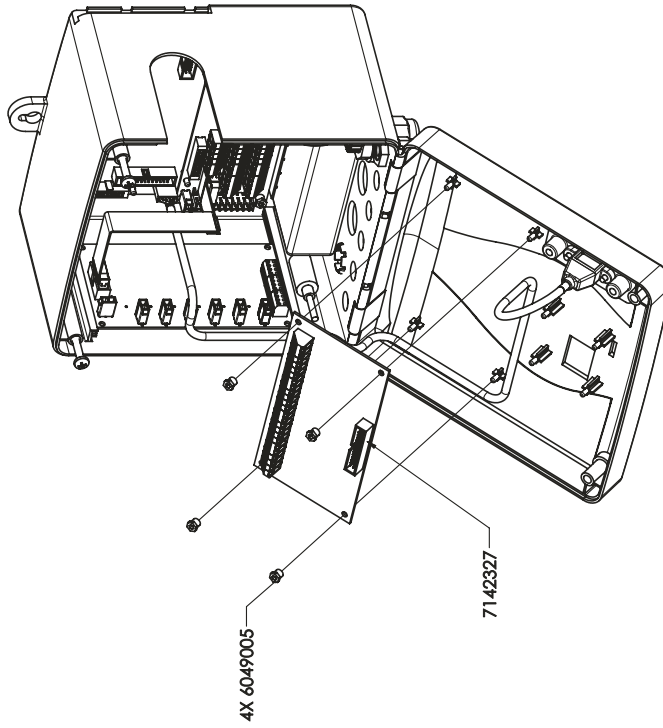

**EURO SIB BOARD**  
**OPTIONAL**

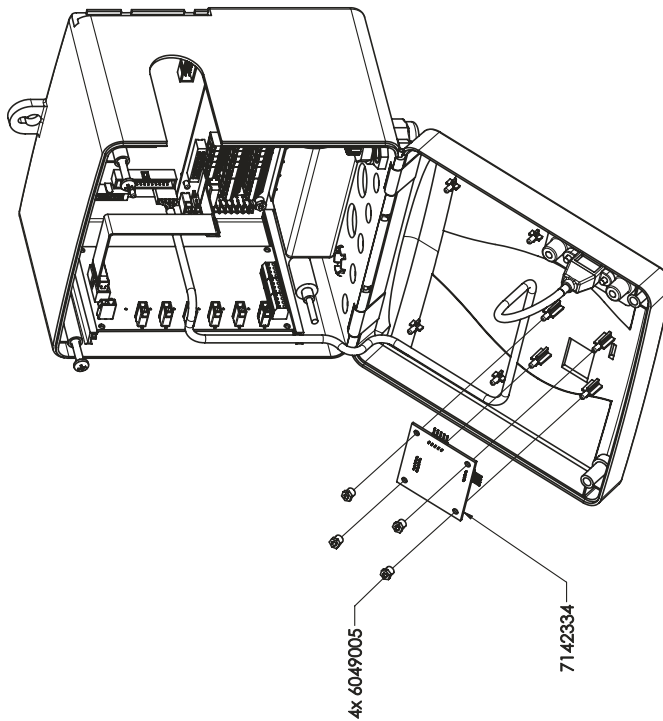

**PRIMING BOARD**  
**OPTIONAL**

# SINGLE WASHER MAIN HOUSING

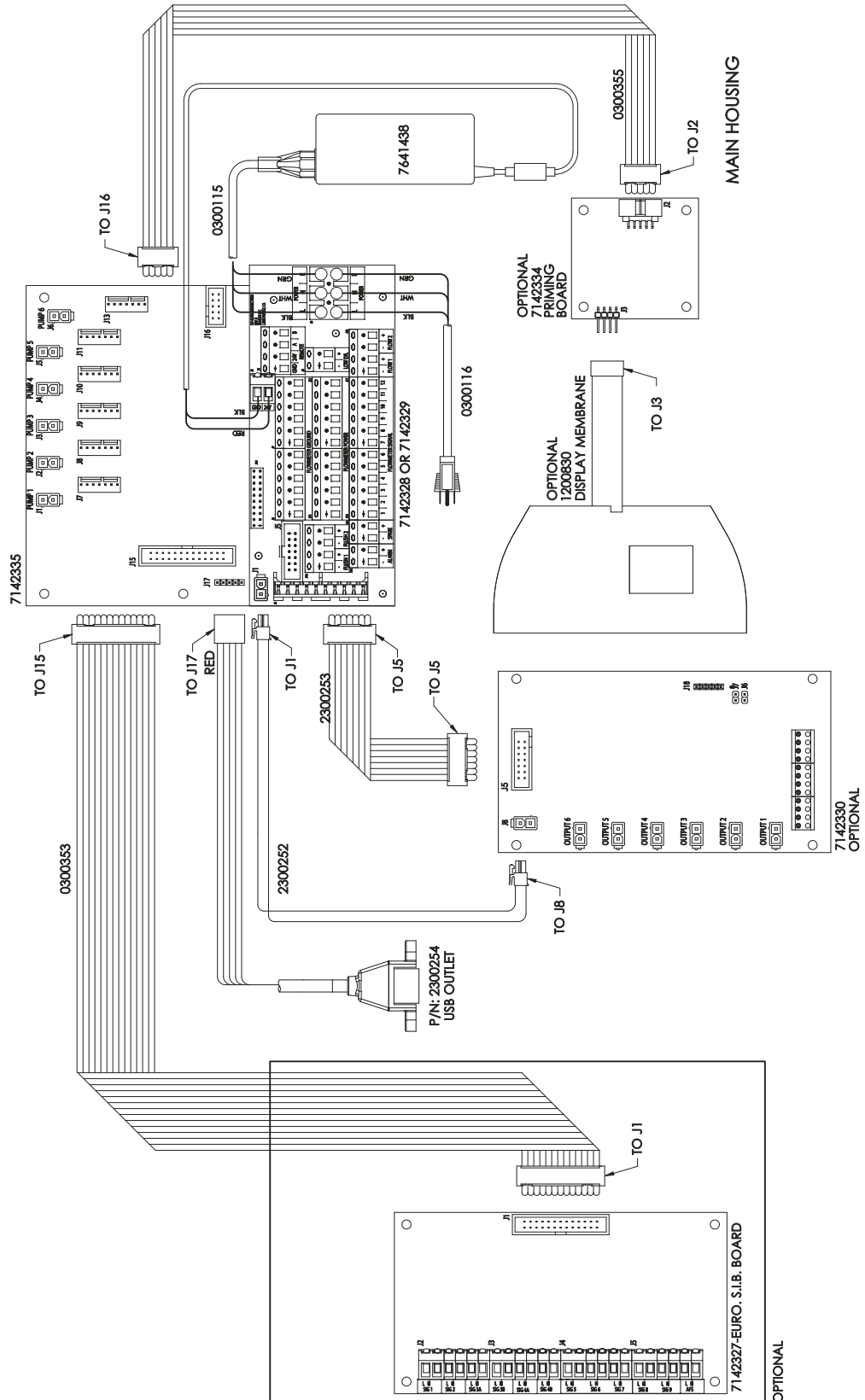

# SINGLE WASHER PUMP CONNECTION

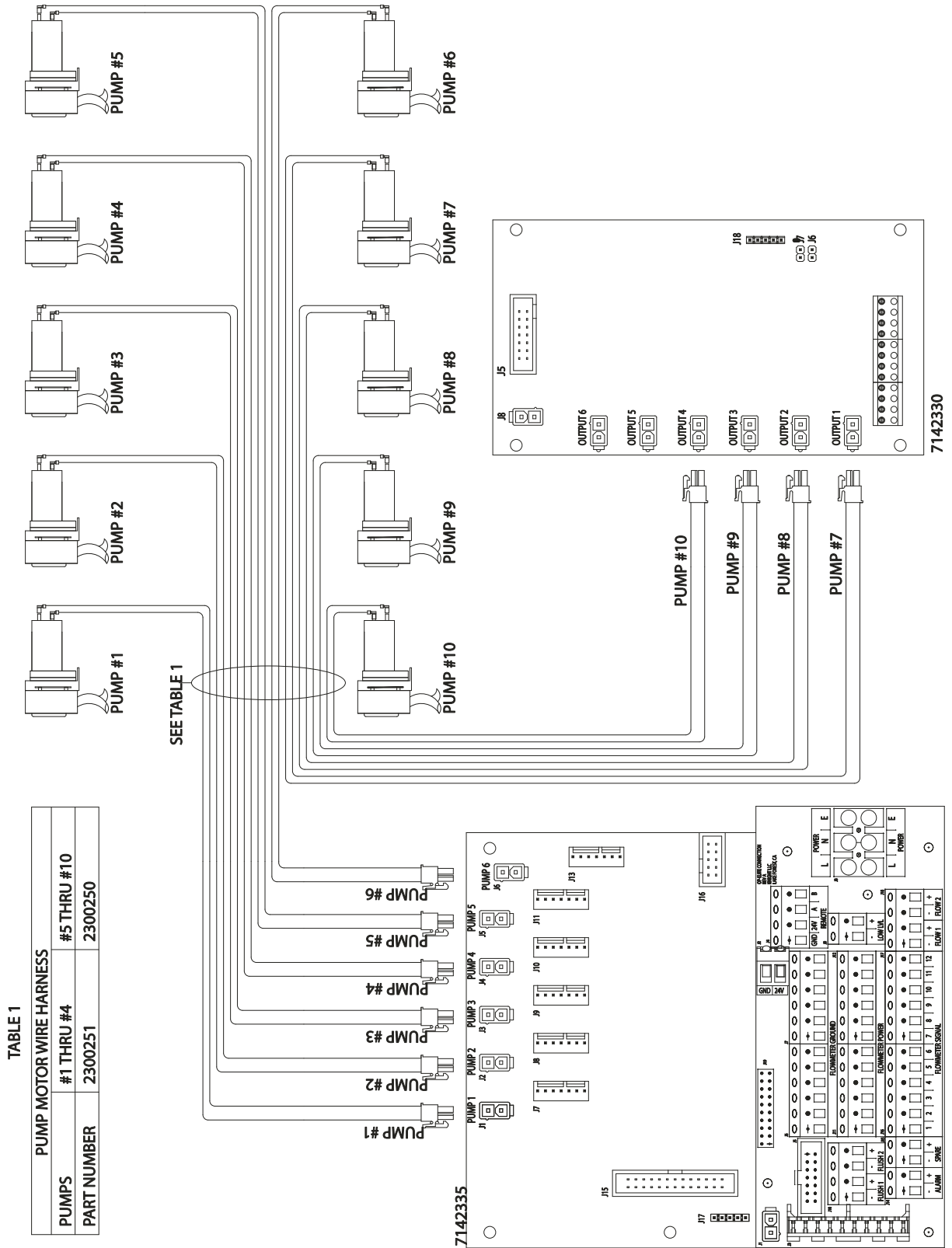
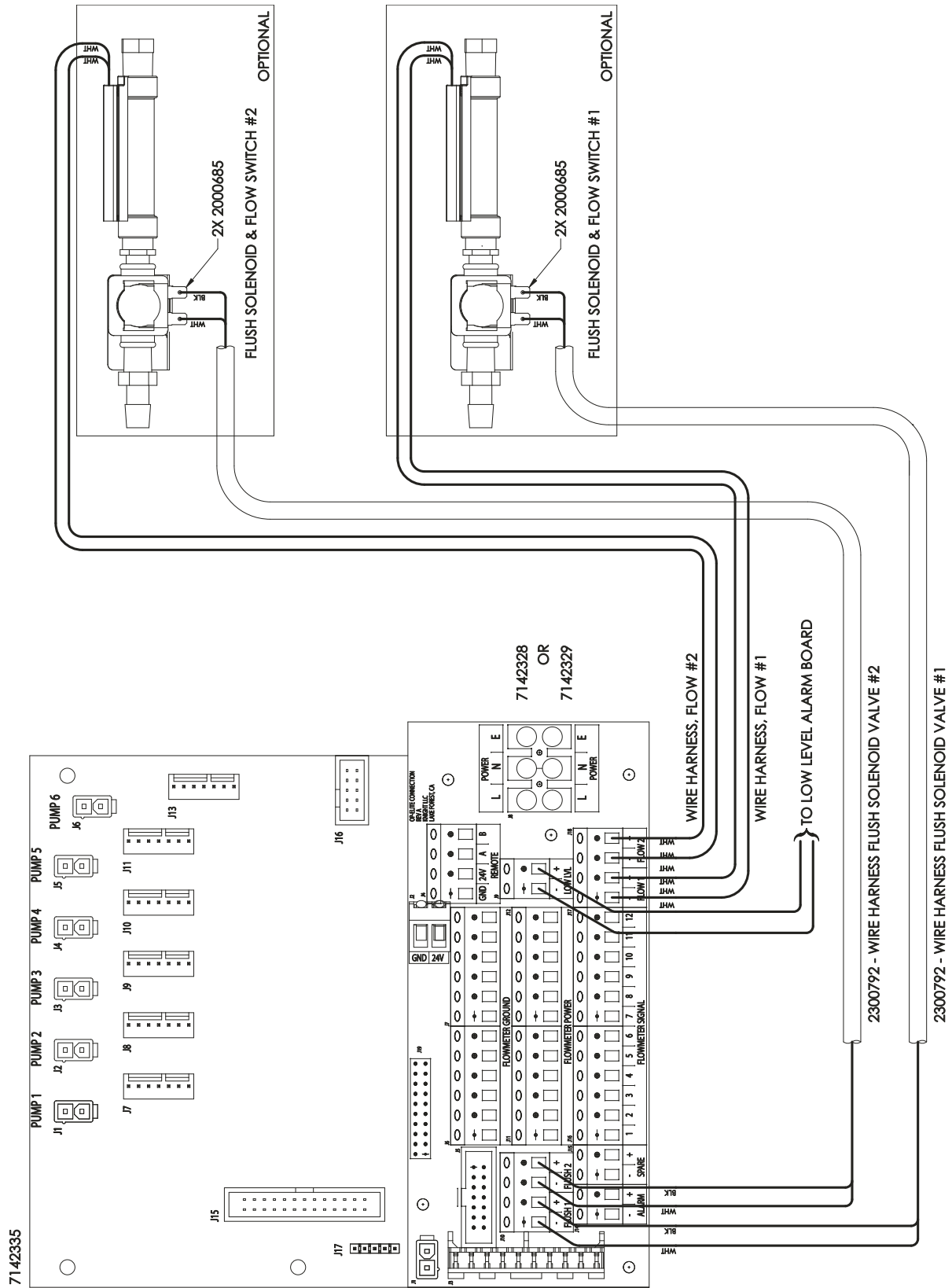

**TABLE 1**

PUMP MOTOR WIRE HARNESS		
PUMPS	#1 THRU #4	#5 THRU #10
PART NUMBER	2300251	2300250



# SINGLE WASHER FLUSH SOLENOID



# SINGLE WASHER FLOW METERS

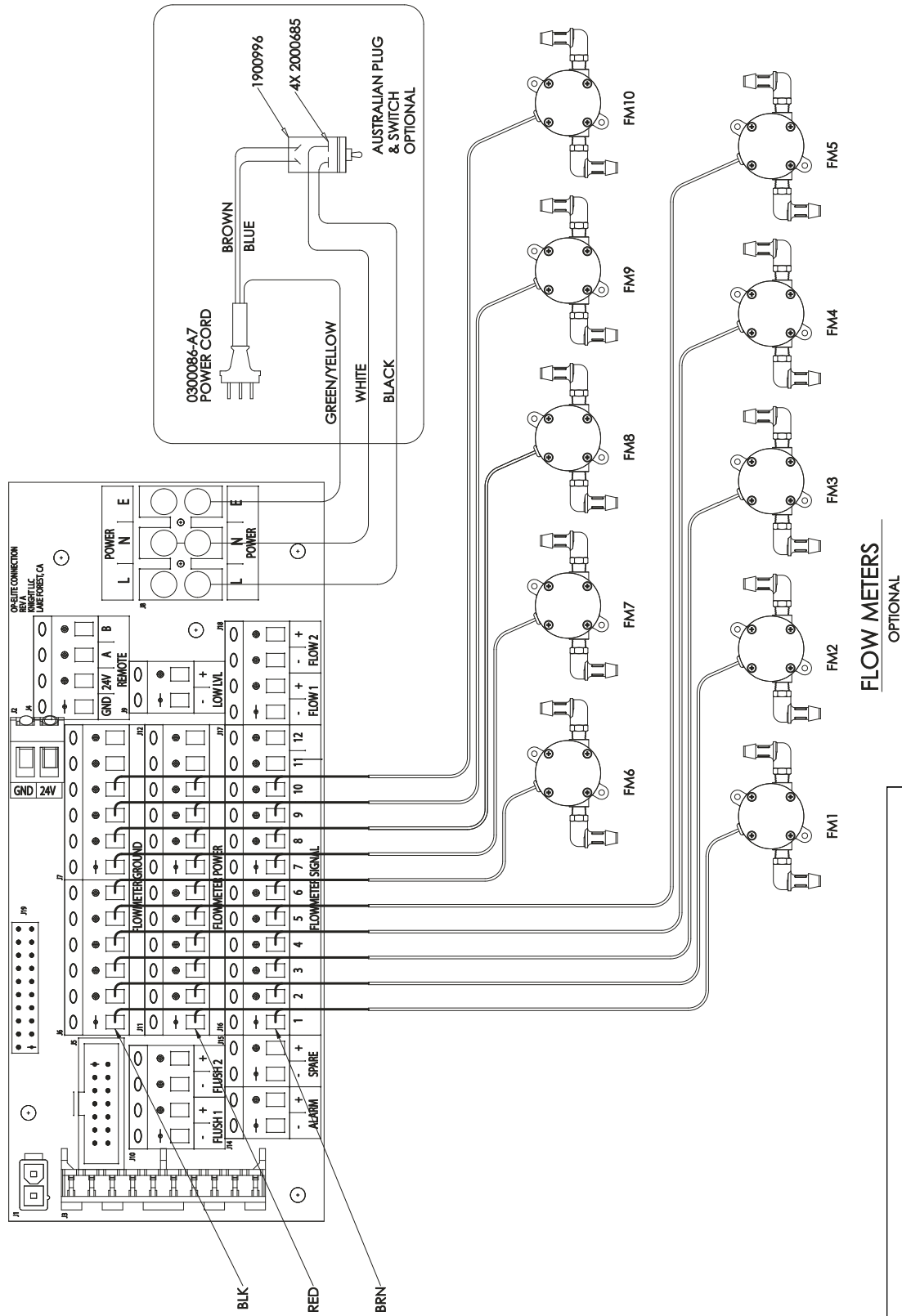

**Warning: Do not use starch with a flow meter! This will cause the flow meter to clog up and stop working.**

# SINGLE WASHER MAIN HOUSING

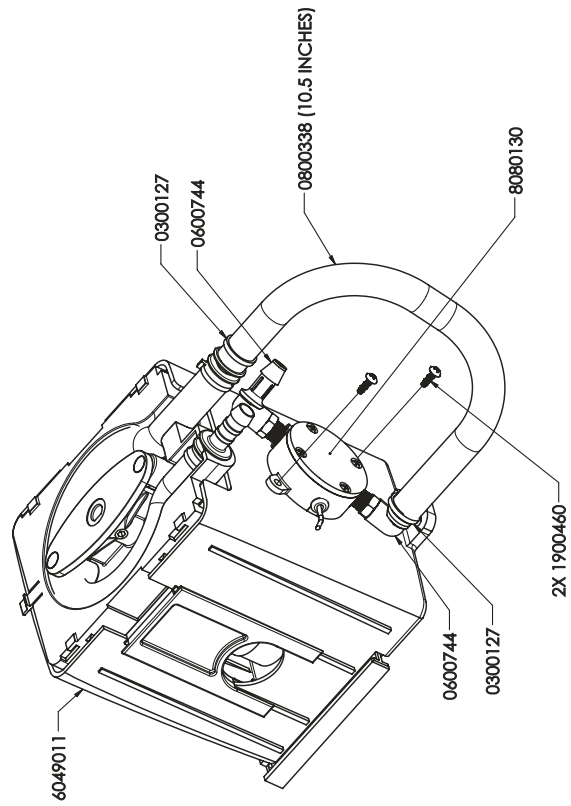

**FLOW METER ASSY DETAIL**  
**800 SERIES PUMP**  
**OPTIONAL**

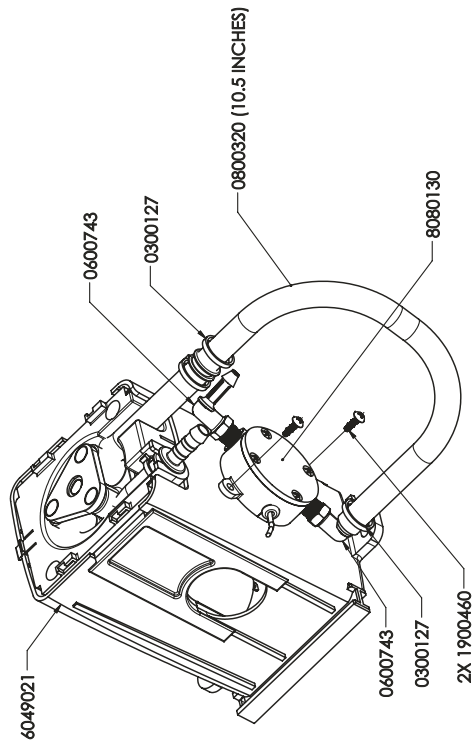

**FLOW METER ASSY DETAIL**  
**500 SERIES PUMP**  
**OPTIONAL**

# DIVERTER VALVES & FLUSH SOLENOID

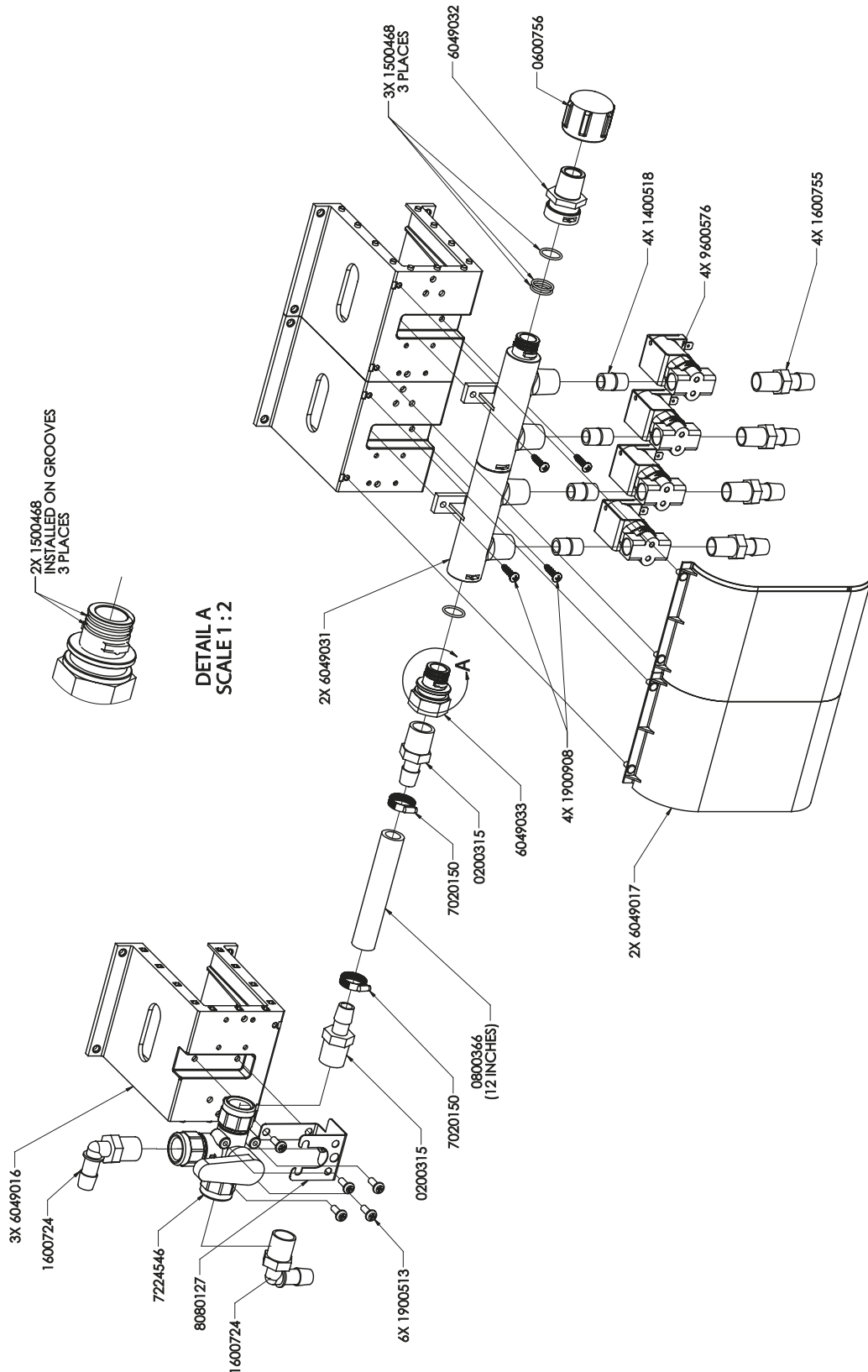



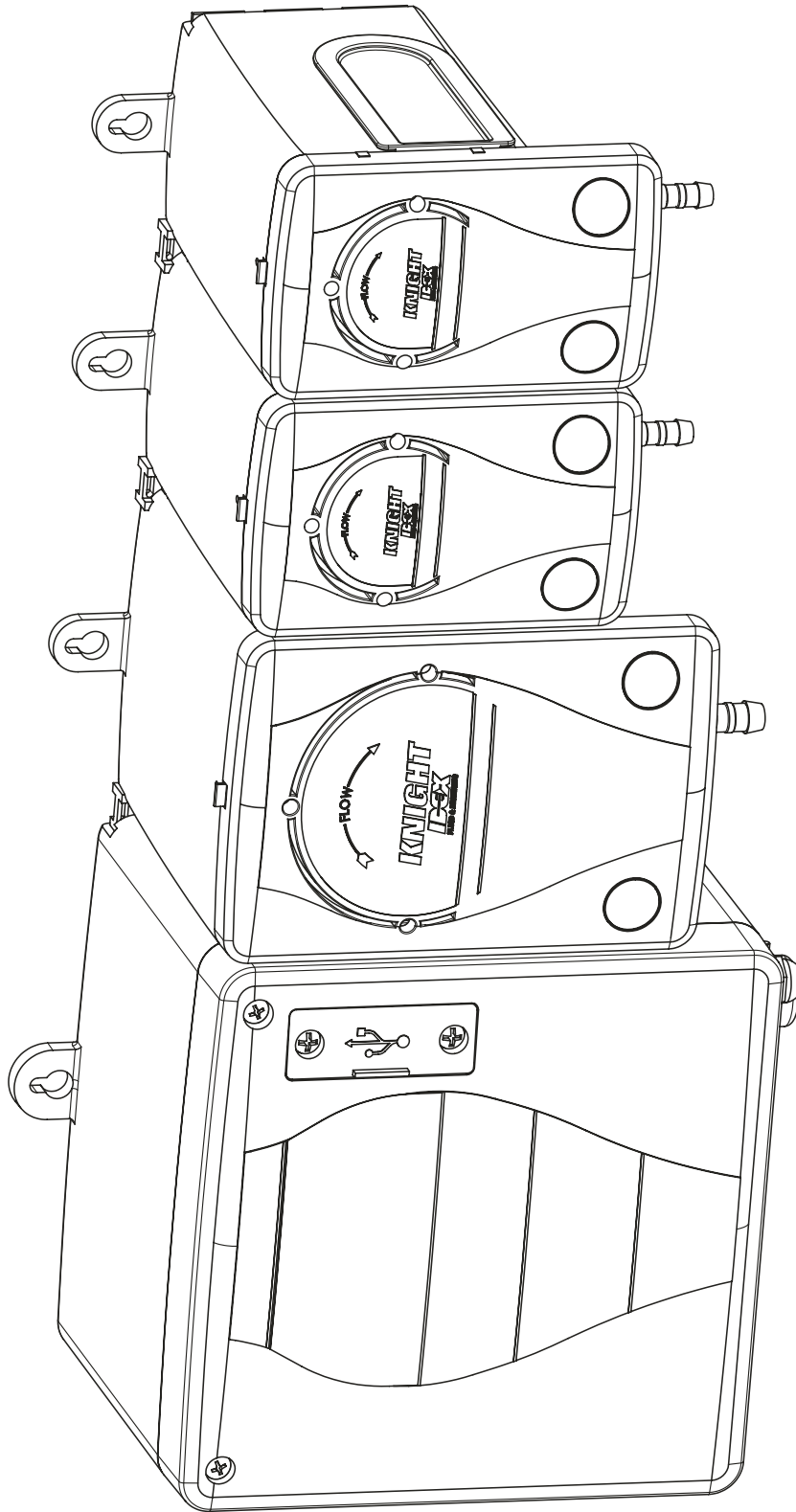

---

**ASSEMBLED UNIT EXAMPLE**



---

## REMOVE / INSTALL PUMP FACE PLATE

-  Removal or installation of the pump face plate for maintenance purposes should **ONLY** be performed by qualified and trained personnel who are considered the Responsible Body for the system.
-  The laundry facility operators of the system should **NEVER** attempt removal or installation of the pump face plate and should be made aware of this by the Responsible Body.
-  The system should **ALWAYS** be put on Maintenance Hold (if system power is ON) during this, or any, maintenance procedures.
-  Access to internal parts are for Responsible Body (i.e. service personnel).

### *Removal*

To remove the face plate, gently push back on the tab and slide the face plate up, then pull it away from the pump assembly.

### *Installation*

Install the face plate into the slots and slide down so that the tab clicks into place.

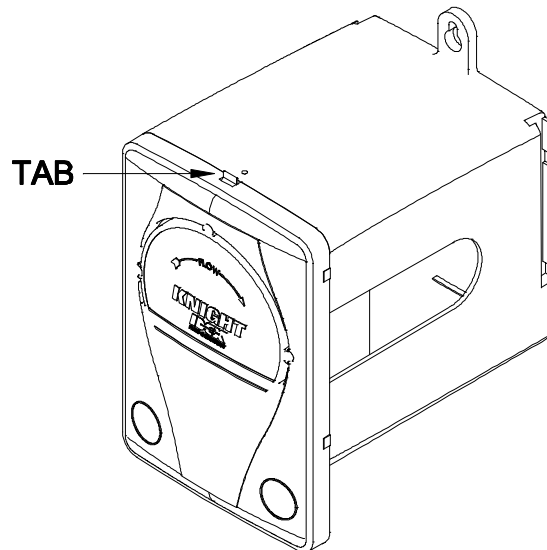

## REPLACING SQUEEZE TUBE

- (1) Bleed any pressure from discharge line.
- (2) Disconnect suction and discharge lines from tube.
- (3) Remove the faceplate of the pump per steps shown above.
- (4) Pull old tube out, being careful not to splash chemical. Insert new tube by squeezing into place.
- (5) Apply a small amount of silicone tube lube to the middle third of the tube where the rollers contact it.
- (6) Put the faceplate back on the pump per steps shown above.
- (7) Re-connect suction and discharge lines from tube.
- (8) Re-calibrate the pump and take note of the new flow rate for future reference

---

## **REMOVE PUMP / CHANGE MOTOR**

### ***Disassembly***

- (1) Bleed any pressure from discharge line.
- (2) Remove the faceplate of the pump.
- (3) Carefully pull the squeeze tube away from the pump ensuring not to disconnect the chemical lines.
- (4) Grasp the roller block and pull the pump assy out from the pump housing.
- (5) Disconnect the motor wires and note or mark the polarity and position by wire color.
- (6) Remove the roller block from the motor shaft
- (7) Remove the 4 screws that hold the motor to the pump body.

### ***Re-assembly***

- (1) Attach the pump body to the new motor with the 4 screws.
- (2) Slide the roller block onto the motor shaft ensuring that is all the way down flush with the pump body.
- (3) Connect the motor wires to the new motor according to the polarity noted in the disassembly steps.
- (4) Carefully slide the pump assy into the case housing by aligning the grooves on the outside of the pump body.
- (5) Insert squeeze tube back into place on pump unit.
- (6) Put the faceplate back on the pump.
- (7) Re-calibrate the pump and take note of the new flow rate for future reference.

## SYSTEM ALARMS

### Flow-meter warnings (10 possible warnings)

- Flow meter Warnings can only occur if a Flush Error is not active.
- All Remotes will change to screen 1 and alarm will sound if the Flow meter pulse rate has reduced below acceptable levels.
- Pressing Enter will clear the Alarm Sound and transition all remotes to Screen 2.
- While in Screen 2, any Flow meter with a reduced pulse rate will dose in Time Mode.
- Screen 2 will transition to Screen 3 if Flow meter's pulse rate increases to acceptable levels and error will clear.
- All Motors dosing in Flow meter Mode will dose based on Flow meter Pulses in Screen 3.
- Screen 1 and 2 Indicates a Flow meter Warning. System will continue to operate without issue during this warning.

```

Load 999 weight 9999 kg
Jan 31, 2012 23:59

Flow-Meter 10 Error
Please Check Chemical
Chemical Name
>Press Enter to Clear
  
```

```

Load 999 weight 9999 kg
Check FM1,2,3,4,5,6,7
Formula Name
Chemical Name
Chemical Name
Chemical Name
>Settings
  
```

```

Load 999 weight 9999 kg
Jan 31, 2012 23:59
Formula Name
Chemical Name
Chemical Name
Chemical Name
>Settings
  
```

### LLA warnings (1 possible warning)

- A LLA Warning can only occur if there are no other active Warnings/Errors.
- If Low Lvl input on the connection board is a closed connection, all remotes will change to Screen 1.
- If Low Lvl input on the connection board is an open connection, all remotes will change to Screen 2.
- Screen 1 Indicates a LLA Warning. System will continue to operate without issue during this warning.

```

Load 999 weight 9999 kg
Low Chemical
Formula Name
Chemical Name
Chemical Name
Chemical Name
>Settings
  
```

```

Load 999 weight 9999 kg
Jan 31, 2012 23:59
Formula Name
Chemical Name
Chemical Name
Chemical Name
>Settings
  
```

### Flush errors (2 possible errors)

- A Flush Error will occur, even when other Warnings are active.
- All Remotes will change to Screen 1 and alarm will sound if the Duration of a Flow switch in an Off state exceeds the Flush Error Delay while the Flush for said Flow switch is running.
- Pressing Enter on Screen 1 will Cause the Remote to Flush for the Flush time to the Washer said remote is connected to.
- Pressing Down on Screen 1 will transition to Screen 2.
- Screens 3 and 4 are available from Screen 2, these screens will allow a user to change the Flush Error Delay time to zero.
- System will not operate until Error has either been eliminated or resolved.

```

Flush [X] Error on
washer ID [XX]
Check water Supply
>Flush
>Disable Flush Error
  
```

```

Flush [X] Error on
washer ID [XX]
Check water Supply
>Flush
>Disable Flush Error
  
```

```

OP-ELITE V XX.XX.XX
ENTER CODE
***
>Back to Error Screen
  
```

```

OP-ELITE V XX.XX.XX
ENTER CODE
***
>Back to Error Screen
  
```



---

## **TROUBLESHOOTING**

### ***Remote control does not light up - power indicator does not come on:***

- Check the power source that the dispenser is connected to.
- Check voltage at power input terminals inside dispenser — refer to wiring diagram.

### ***Pumps do not trigger from signals:***

- Check signal voltage and duration.
- Check for flush error — press RESET to clear.
- Check pump run and delay time settings.
- Pump may be counting down a "lockout" time (if used) from a previous activation.
- Pump may be trying to activate its "second level" feature (this applies to pumps 1 - 6 only).
- System may be set for Drain Mode, which requires pumps to have a drain number assignment to activate.

### ***Pumps will not turn when trying to prime, or during a washcycle:***

- Check for loose pump motor wires.
- Check for voltage from circuit board to motor.
- Check for mechanical binding of moving parts.

### ***System hangs up with Knight/IDEX logo showing on the display:***

- Check SIB address DIP switch settings to ensure that you do not have a duplicate address.
- Check SIB address DIP switch settings to ensure that they match the settings in the programming menus.
- Verify wiring.

### ***Flush errors keep occurring:***

- Check to see if a flush manifold is used — if so, is it operating correctly?
- Check flow switch for proper connection to dispenser and proper water flow.

### ***Pumps run but do not dispense product:***

- Check product containers.
- Check squeeze tube for wear.
- Check condition of roller and pump housing.
- Check for air leaks) on suction line.
- Check for blockage from pump tube into flush manifold (if used).

### ***Pumps trigger more than once during cycle:***

- Check supply signal input for repeat signals from washmachine.
- Check signal lock-out function.

### ***All pumps run at the same time.***

- Check signals from washmachine.
- Check the settings for assigned signal mode (if used).

---

**NOTES**

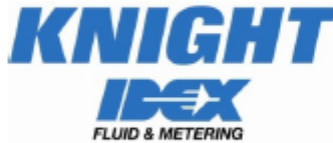

KNIGHT, LLC  
A Unit of IDEX Corporation  
20531 Crescent Bay Drive  
Lake Forest, CA 92630-8825  
Phone: (949)595-4800  
Fax: (949)595-4801  
www.knightequip.com

## EC – Declaration of Conformity

We declare that the product listed below, to which this Declaration of Conformity relates, is in conformity with the Standards and other Normative Documents listed below:

**Equipment Description:** Advanced Laundry Chemical Dosing System for Single and Multi-Washers  
**Type/Model Number:** On-Premise Elite

**Low Voltage Directive - 2006/95/EC (and former Directive 73/23/EEC)**  
Standards to which Conformity is Declared:

**Electrical Safety** IEC 61010-1 (2<sup>nd</sup> Ed). EN 61010-1 (2<sup>nd</sup> Ed) - Safety Requirements for Electrical Equipment for Measurement, Control, and Laboratory Use, Part 1: General Requirements.

**For Information:** The "Electrical Safety Test" took place at the CSA International, Irvine, CA, U.S.A

**Electromagnetic Compatibility**  
EMC Directive - 2004/108/EC and former Directive 89/336/EEC as amended by 92/31/EEC and 93/68/EEC  
Standards to which Conformity is Declared:

**EMC Emissions:** CISPR 11: Industrial, scientific and medical (ISM) radio-frequency  
EN 55011: Equipment - Radio disturbance characteristics - Limits and methods of measurement

EN 61000-3-2: Limits for harmonic current emissions  
EN 61000-3-3: Limitation of voltage changes, voltage fluctuations and flicker in public

**EMC Immunity:** EN 61326-1: 2006 Electrical Equipment Measurement, Control & Laboratory Use (Normal Environment)  
EN 61000-4-2: Electrostatic discharge immunity test  
EN 61000-4-3: Radiated, radio-frequency, electromagnetic field immunity test  
EN 61000-4-4: Electrical fast transient/burst immunity test  
EN 61000-4-5: Surge immunity test  
EN 61000-4-6: Immunity to conducted disturbances, induced by diode frequency fields  
EN 61000-4-11: Voltage dips, short interruptions and voltage variations immunity test

**For Information:** The "Electromagnetic Test" took place at the Aegis Labs., Lake Forest, CA, U.S.A

**Certification Marking:** 

We declared that the equipment specified above conforms to the referenced EU Directives and Harmonized Standards."

Signature:  Date: 08/07/2013

Name: John Chiechi Title: Director of Engineering

---

## **DISCLAIMER**

Knight LLC does not accept responsibility for the mishandling, misuse, or non-performance of the described items when used for purposes other than those specified in the instructions. For hazardous materials information consult label, MSDS, or Knight LLC. Knight products are not for use in potentially explosive environments. Any use of our equipment in such an environment is at the risk of the user, Knight does not accept any liability in such circumstances.

## **WARRANTY**

All Knight controls and pump systems are warranted against defects in material and workmanship for a period of ONE year. All electronic control boards have a TWO year warranty. Warranty applies only to the replacement or repair of such parts when returned to factory with a Knight Return Authorization (KRA) number, freight prepaid, and found to be defective upon factory authorized inspection. Bearings and pump seals or rubber and synthetic rubber parts such as "O" rings, diaphragms, squeeze tubing, and gaskets are considered expendable and are not covered under warranty. Warranty does not cover liability resulting from performance of this equipment nor the labor to replace this equipment. Product abuse or misuse voids warranty.

## **FOOTNOTE**

The information and specifications included in this publication were in effect at the time of approval for printing. Knight LLC reserves the right, however, to discontinue or change specifications or design at any time without notice and without incurring any obligation whatsoever.

---

**KNIGHT LLC, A Unit of IDEX Corporation ([www.knightequip.com](http://www.knightequip.com))**

<b>Knight Headquarters</b> Tel: 949.595.4800 Fax: 949.595.4801	<b>USA Toll Free</b> Tel: 800.854.3764 Fax: 800.752.9518	<b>Knight Canada</b> Tel: 905.542.2333 Fax: 905.542.1536	<b>Knight Europe</b> Tel: 0044.1323.514855 Fax: 0044.1323.514828	<b>Knight Australia</b> Tel: 61.02.9352.1801 Fax: 61.02.9352.1899	<b>Knight N. Asia</b> Tel: 82.2.3481.6683 Fax: 82.2.3482.5742	<b>Knight S. Asia</b> Tel: 65.6763.6633 Fax: 65.6489.6723
--	--	--	--	---	---	---

---