

Control Guard ACCS Instruction Manual

TABLE OF CONTENTS

Safety Precautions	3
Specifications	3
Indication For Use	4
Installation	5-6
Language Selection.....	7
System Programming	8
System Settings Menu.....	9-11
Sensor Settings Menu	12-13
Pump Settings Menu	14-22
Error Screens	23
PC Application Programming.....	24-33
System Dimensions.....	34
Wiring Diagrams	35-42
Exploded View Drawings.....	43-49
Troubleshooting.....	50
Declaration of Conformity	51
Warranty Information	52
Knight Locations	52



CAUTION: Wear protective clothing and eyewear when dispensing chemicals or other materials. Observe safety handling instructions (MSDS) of chemical mfrs.



CAUTION: To avoid severe or fatal shock, always disconnect main power when servicing the unit.



CAUTION: When installing any equipment, ensure that all national and local safety, electrical, and plumbing codes are met.

SAFETY PRECAUTIONS

- Wear protective clothing and eye protection whenever operating this system.
- Wear protective clothing and eye wear when dispensing chemicals. Observe safe handling instructions (MSDS) provided on chemical container or as supplied by chemical manufacturer.
- To avoid severe or fatal shock, physical injury, always disconnect main power when servicing the unit.
- When installing any equipment, ensure that all national and local safety, electrical and plumbing codes are met.
- Do not submerge or place in direct path of spray/moisture.
- Only approved, factory authorized technicians to service unit.

SPECIFICATIONS

Cabinet Materials	Case / Cover: ABS UL94 V-0 Pump Faceplate: Lexan 9945A UL94 v-0
Case Ratings	IP-65 (Protected from total dust ingress, and low pressure water jets from any direction)
Dimensions	W 18" x H 10.5" x D 8" (46 cm x 27 cm x 20 cm)
Standard Power Supply	Input: 100 - 120 VAC 50/60 Hz (3.0 A) Input: 200 - 240 VAC 50/60 Hz (2.0 A) Output: 24 VDC (6.5 A)
High Current Power Supply	Input: 100 - 120 VAC 50/60 Hz (4.5 A) Input: 200 - 240 VAC 50/60 Hz (2.5 A) Output: 24 VDC (8.8 A)
Unit Weight	30 lbs (13.6 kg)
Pump Flow Rates (note 1)	3.38 - 38.9 oz/min (100 - 1150 ml/min)
Pump Duty Cycle (note 2)	50% (based on 10 min operating window)
Maximum Pump Run Time (note 2)	5 Minutes
Maximum Pump Lift / Suction	10 Feet (3 Meters)
Maximum Pump Head Pressure	30 PSI (2 Bar)
Certifications	CAN/CSA-C22.2 No. 61010-1-12 UL Std No. 61010-1 (3rd Edition) EN 61010-1: 2010 (3rd edition)



Specification Notes

- (1) The pump flow rates shown in the specification table were established using water at ambient temperatures with zero discharge pressure. Pump settings from 20% to 100%.
- (2) The duty cycle and maximum pump run time specified above can be exceeded, however in doing so the life of the squeeze tube, roller block and motor may be reduced.

Peristaltic Pump Accuracy

+/- 5% when not calibrated at use volume on up to 128oz
 +/- 2% when calibrated at use volume on up to 128oz

Equipment Ratings

- Pollution degree, 2
- Installation category, II
- Altitude, 2000 meters (max)
- Humidity, 95% Rh (max)
- Electrical supply input 100 - 240 VAC 50/60 Hz(see specifications above)
- Mains supply voltage fluctuations up to $\pm 10\%$
- System is for indoor use only
- Maximum Ambient Temperature: 40 °C

INDICATION FOR USE

The Control Guard ACCS (Advanced Chemical Concentration System) is designed with ease of setup and use in mind. By utilizing flow meter technology, the ACCS measures high concentrations of caustic, acid, rinse water or other liquids with an extremely high degree of accuracy (+/- 2%) thereby ensuring precise chemical feed control. The Control Guard offers multiple 4-20 mA analog inputs which provide the flexibility of being utilized by any "Off the Shelf" probe whether it is pH, ORP, conductivity or other analytical measurements from a variety of popular manufacturers (Rosemount, Sensorex, etc.). These features can be maximized by employing the Control Guard's distinctive data logging and reporting capabilities.

The Control Guard ACCS has the ability to operate up to 3 pumps of various designs including: Peristaltic, Air Operated Diaphragm (AOD) and Electric Diaphragm Pumps (EDP). These can be employed in any of 4 modes of operation (signal, relay, repeat cycle and probe - see full details below) either in conjunction or independently of one another. This allows for more complete and accurate control of your CIP process.

The improved user interface employs an enhanced 64X128 RGB backlit display that is combined with our easy to program 4 button control keypad which makes programming extremely user friendly and reduces the amount of set up time while providing critical process information with just a quick glance. With data management and subsequent reports playing a crucial role in today's process environment the Control Guard ACCS enables Sanitation Managers to clearly address process parameters and status conditions with accurate reports as required by current regulatory requirements.

Modes of Operation

- **Signal Mode** - This mode of operation will run the pump to deliver a specific chemical dosage when triggered by an activation signal. The pump can be delayed, if required, for applications where the chemical delivery needs to happen at a later time from when the trigger signal is received. Lastly, the pump can be locked out for a specific time frame after delivery to prevent accidental repeat dosages.
- **Relay Mode** - This mode of operation will run the pump for as long as a trigger signal is applied. Use of this mode is intended for applications where the duration of the trigger signal is controlled by another source and the Control Guard is utilized as a slave pump. The chemical dosage is tracked by how long the pump has run for a specific time. The pump can stop briefly during the time that the dosage is being tracked. After the specified time has elapsed, the dosage is then logged into memory for reporting purposes.
- **Repeat Cycle Mode** - This mode of operation has two separate chemical dosages referred to as initial charge and recharge. When the trigger signal is first applied, the initial charge is activated. The system then counts down a recharge time after which the recharge volume will be dispensed. The recharge time and recharge volume continue to repeat activations until the trigger signal turns off.
- **Probe Mode** - This mode of operation utilizes a probe (inductive or analog input) to sense and maintain the chemical concentration based on a programmed value. When the probe detects that the concentration has fallen below the programmed setpoint, the pump will turn on to regain the setpoint. While the pump is running, the alarm delay is monitoring the time that it takes to get the solution back to the setpoint. If the setpoint cannot be reached within the alarm delay period, the alarm will sound to notify there is a problem. The feed limit setting controls whether the pump should continue to run, or stop, when the alarm is active. The pulse percent and pulse rate settings control how the pump will "pulse feed" when close to the setpoint value.

PRE-INSTALLATION SITE SURVEY

- (1) Check all applicable plumbing and electrical codes before installation. This will help to ensure that the system is installed in safe and suitable manner.
- (2) Get a wiring schematic of the equipment that the Control Guard will connect to.
- (3) Check to make sure that all functions of the equipment are operating properly. This may include; PLCs, timers, water solenoids, water level switch, and pump motor.
- (4) Check the proposed location for a 115, or 230 VAC power source (based on the model you will be using).
- (5) Check voltage of all signals that will be used. Measure voltage between the signal and signal common with a voltmeter. Do not check signal voltage between signal and earth ground.
- (6) Check mounting location for chemical injection fittings. Verify the port size with fittings you have for installation.

PRE-INSTALLATION CHECKLIST

Before beginning the installation, make sure you have the tools and materials listed below:

- Flat and Phillips screwdrivers
- Drill and drill bits
- Wire cutters, wire strippers, and pliers
- Voltmeter (or multi-meter)
- Level
- Suitable wire for power / signals (check local codes)
- Dry wall inserts and mounting screws
- Electrical tape and wire nuts
- Braided vinyl hose
- Chemical test kit

INSTALLATION

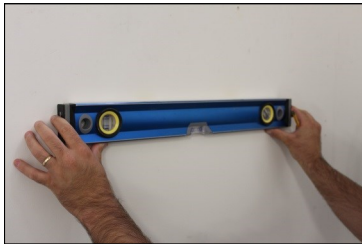

(1) Position level on wall at the desired mounting location.



(2) Draw line across top of level approximately 20" long.



(3) Check that line is visible.

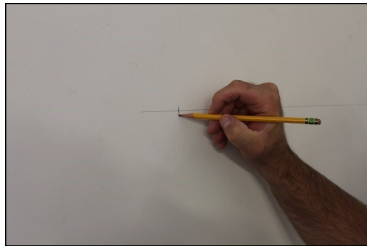

(4) Mark position of first hole for mounting screw.

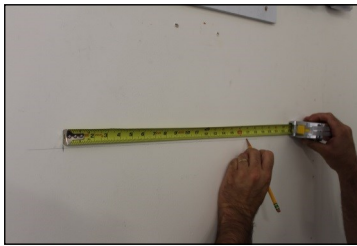

(5) Use a tape measure and mark second hole at 17".



(6) Drill 3/16" holes in the two marked positions.



(7) Tap wall anchors into both holes.



(8) Insert screws into anchors leaving 1/4" space.



(9) Hang unit on screws through the upper two keyholes.



(10) Mark position of lower two keyholes.



(11) Remove unit and drill holes for lower two positions.



(12) Insert anchors / screws as done in steps 7 and 8.

INSTALLATION



(13) Hang unit and tighten all four mounting screws.



(14) Loosen two cover screws.

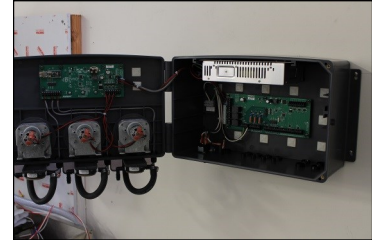

(15) Pull gently on cover latch (right side) to open unit.

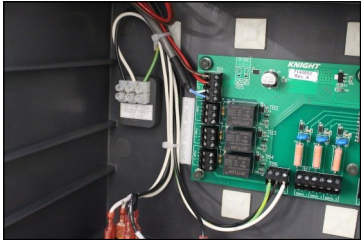

(16) Note the location of main power terminal block.

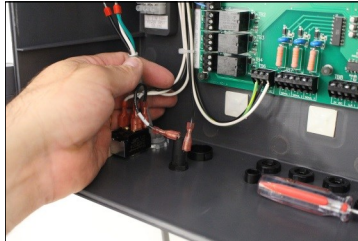

(17) Feed main power wires through conduit fitting.

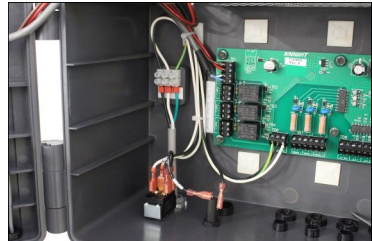

(18) See main power connection details below.

Main Power Connection

Connect 115 VAC or 240 VAC power source to main power connection in pump cabinet. Use suitable conduit for electrical wiring (per applicable wiring codes). A suitable ground conductor should be connected to the ground terminal in accordance with local electrical codes. The user/installer should provide a disconnect switch or circuit breaker close to the equipment and should be marked that it is for this equipment.

Note: Make sure that all conduit connections are water tight.

Inductive Probe Installation (optional)

NOTE: Use only a 200 mS inductive probe (Knight P/N 6536034) with this unit. Control will not operate properly above 200 mS.

- (1) The probe should be mounted in the washer tank with the hole oriented vertically. Start by feeding the wire end through the mounting hole from the inside of the tank. Use a rubber washer on the threaded mounting stud. Secure with the mounting nut on the outside of the tank.
- (2) After the plastic probe body has been firmly secured to the mounting hole with a rubber washer and nut, feed the wire lead through a strain relief on the bottom of the Control Guard unit.
- (3) With the wire lead routed through the strain relief, attach the four wires to the circuit board per the wiring diagram. The wire colors must match the colors shown on the terminal strip.

Peristaltic Pump Connections

- (1) Cut a suitable length of 3/8" ID braided tubing and connect between the discharge (right) side of the pump's squeeze tube and the injection point. Use 3/8" ID barb fittings (supplied) and hose clamps to secure safely.
- (2) Cut a suitable length of 3/8" ID braided tubing and connect between the suction (left) side of the pump's squeeze tube and the chemical pickup tube. Use of barb fittings and hose clamps is recommended.
- (3) Insert pickup tube into chemical container.

PRIMING PUMPS

Use the ▲ and ▼ keys to highlight the pump you want to prime. Press the ENTER key.

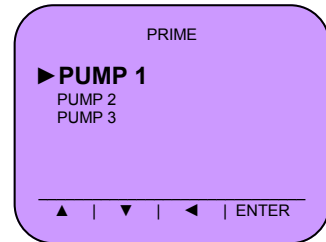
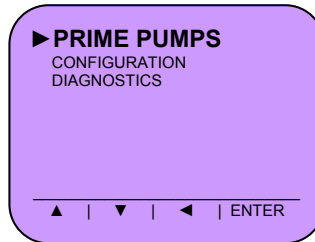

Use the keys directly below the START to turn the pump on and begin priming. When fully primed use the key directly below the STOP to turn the pump off. Repeat as necessary for other pumps.

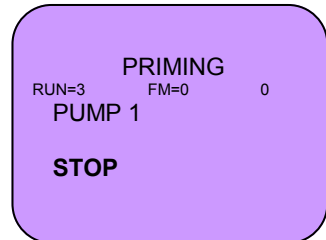
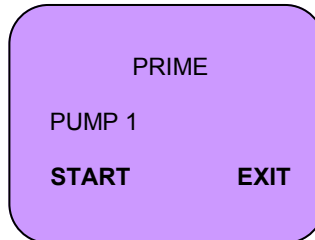

LANGUAGE SELECTION

To change the main home screen and first menu language from English to Spanish press the key directly below "IDIOMA"

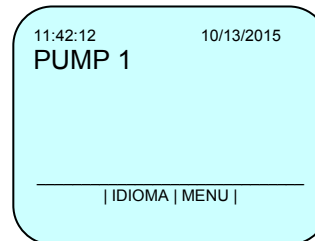

The first menu screen will also appear in Spanish for priming pumps. Use the ▲ and ▼ keys to highlight the pump you want to prime. Press the ENTER key.

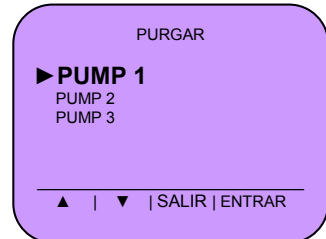
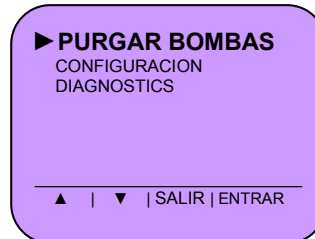

Use the keys directly below the START to turn the pump on and begin priming. When fully primed use the key directly below the STOP to turn the pump off. Repeat as necessary for other pumps.

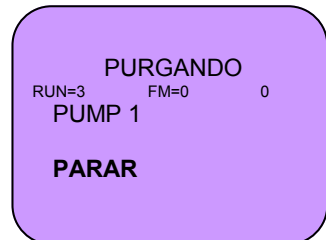
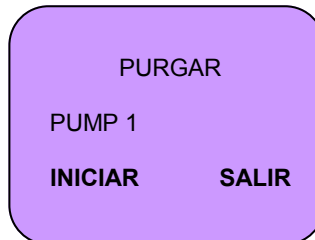

To change back to English press the key directly below "LANG".

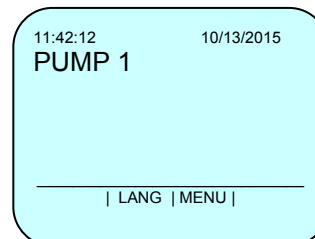

SYSTEM PROGRAMMING

The system operates using a 4 button key design. The key functions are controlled via the firmware and are specific to each screen. The main 4 keys are MENU, UP, DOWN and ENTER. The ENTER key is used to move the cursor and select within the menu functions. The UP and DOWN arrows are used to change a value. Changed values will be saved upon exiting the current menu function. The screen has 4 colors to easily identify the system status.

- BLUE - Run Mode
- PURPLE - Programming Mode
- GREEN - Performing a Function
- RED - Error Display



Accessing the Programming Menus

When power is first applied you will see the screen showing the CONTROL GUARD name along with USB and firmware versions. You will then see the main run screen which shows the status of any pump action.

Press the MENU button to access the settings menu. Press the ▼ key to highlight CONFIGURATION. Press the ENTER key.

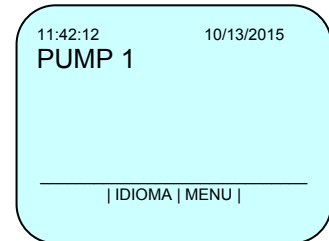

Password Protection

A private password protects the system settings and allows only authorized personnel to make programming changes.

To enter a private password, press ENTER key to move the cursor, then UP or DOWN to change the value. Once you press ENTER after the last digit it will take you to the next screen. The default code is: 0000.

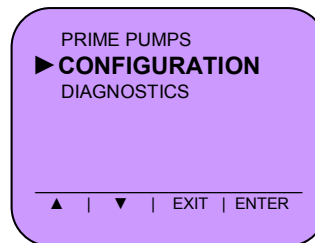

If the wrong password is entered it will take you back to the main run screen. If you have forgotten your password, you can call Knight and give them the 4 digit bypass code and they can give you a one-time password.

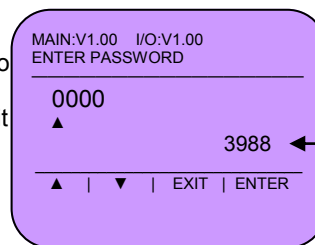

4 digit bypass code

SYSTEM SETTINGS MENU

Use the ▲ and ▼ key to highlight SYSTEM SETTINGS, then press ENTER.

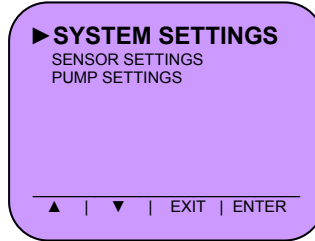

USB Functions

Use the USB FUNCTIONS to save reports, download a setup file created on the PC application to the machine, upload a setup file created on the machine to save in the PC application, or to clear report data.

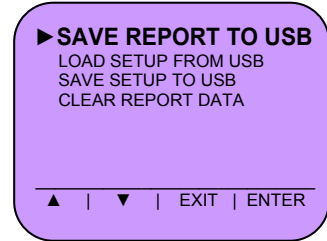
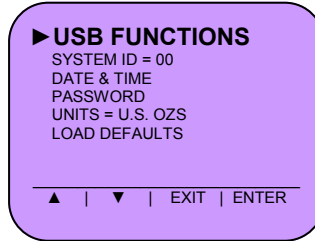

Saving Reports

With SAVE REPORT TO USB highlighted press the enter key. You can then choose your start and end dates followed by pressing ENTER. The screen will change to light green while the report is being saved.

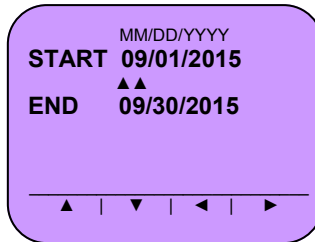

Loading Setup

With LOAD SETUP FROM USB highlighted press the enter key. The screen will change to light green and ask if you are sure you want to load the setup file from the USB. Press the YES key to load the setup file. Press the NO key to cancel.

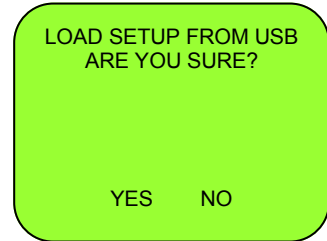
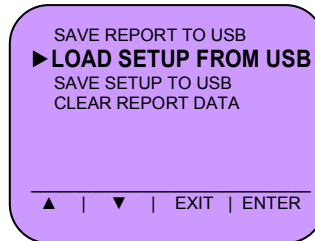

NOTE: The system will search the USB drive for the setup file with the matching SYSTEM ID. If the SYSTEM ID does not match you will get an error screen. See error screen messages on the following page for details.

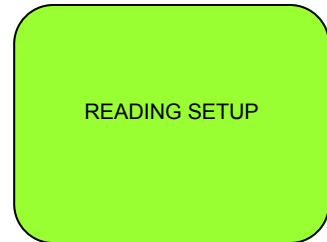

If you pressed the YES key you will see the following screens during the download. Once completed the system will return to the main menu screen (purple).



Saving Setup

With SAVE SETUP TO USB highlighted press the enter key. The screen will change to light green and ask if you are sure you want to save the setup file to the USB. Press the YES key to save the setup file. Press the NO key to cancel.

If you pressed the YES key you will see the following screen during the download. Once completed the system will return to the main menu screen (purple).

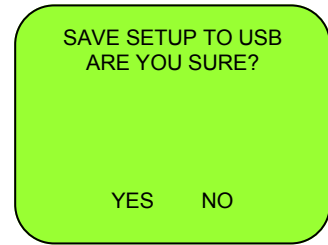
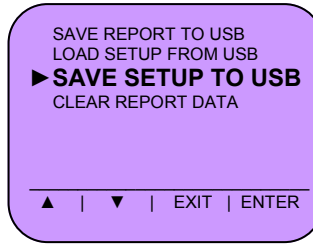

Clear Report Data

With CLEAR REPORT DATA highlighted press the enter key. The screen will change to light green and ask if you are sure you want to clear data. Press the YES key to clear. Press the NO key to cancel.

If you pressed the YES key you will see the following screen while clearing. Once completed the system will return to the main menu screen (purple).

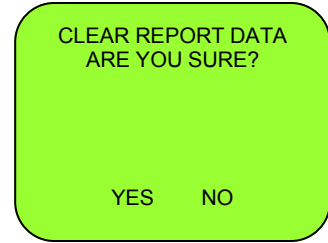
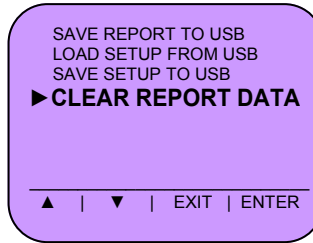

USB Errors

If no USB device is installed during the loading or saving of a setup file you will get a "ERROR READING FILE" screen when loading or an "ERROR WRITING FILE" screen in red. Press any key to get back to the main menu. Check to make sure you installed a USB device.

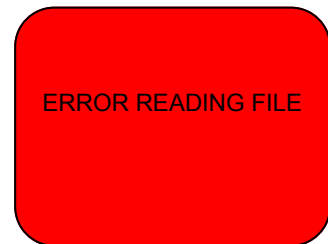

System ID

Use the ENTER key to move the cursor (▲) to the setting you want to change. Use the ▲ and ▼ keys to make changes. Once you get to the last setting press the ENTER key to save and exit to the main menu. Use the MENU key to exit without saving. See page 25 for details on System ID.

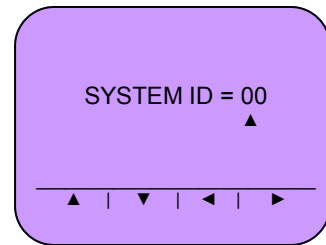
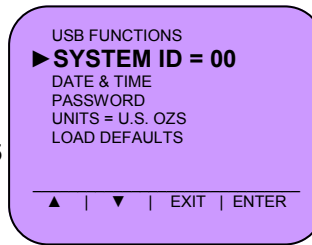

Date & Time

Use the ENTER key to move the cursor (▲▲) to the setting you want to change. Use the ▲ and ▼ keys to make changes. Once you get to the last setting press the ENTER key to save and exit to the main menu. Use the MENU key to exit without saving.

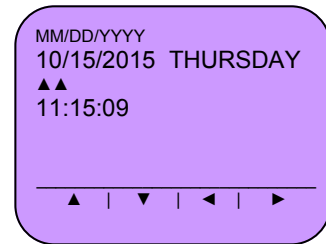
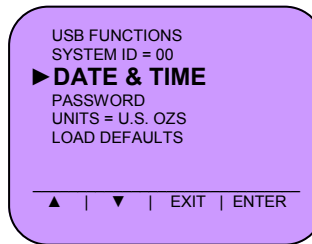

Password

To change the private password, press ENTER key to move the cursor, then UP or DOWN to change the value. Once you press ENTER after the last digit it will take you to the next screen. The default code is: 0000. Use the MENU key to exit without saving.

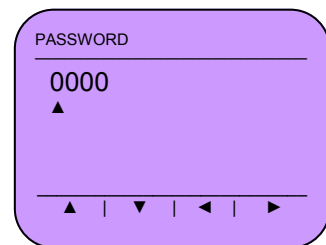
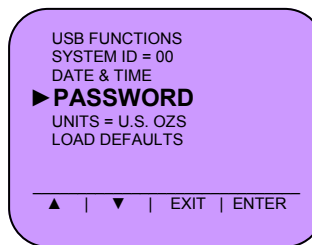

Units

To select the units of measure use the keys directly below the "METRIC" or "U.S. OZS". Once selected you will return to the settings screen.

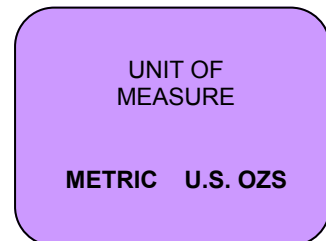
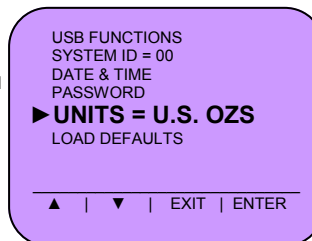

Load Defaults

To load default settings use the keys directly below the "YES" and "NO". Once selected the system will restore all settings to their default values.

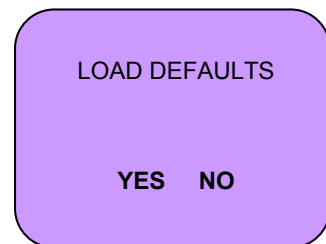
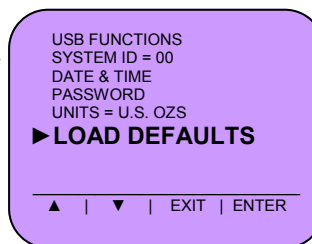

SENSOR SETTINGS MENU

Highlight SENSOR SETTINGS, then press ENTER. Use ▲ and ▼ to highlight the probe you wish to change, then press ENTER.

Choose the MORE SETTINGS option to skip the probe settings and go directly to analog inputs.

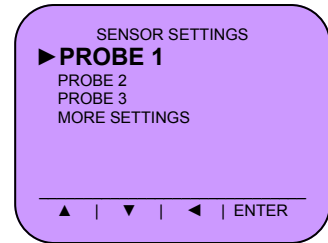
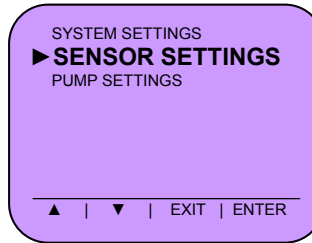

Probe Name

This setting allows you to change the name of each probe independently. You have a maximum of 12 characters. Use ▲ and ▼ to change the letters of the probe name, then press ENTER.

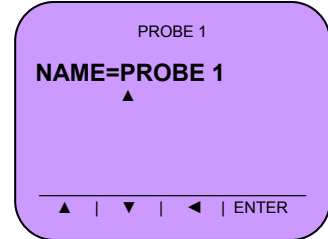
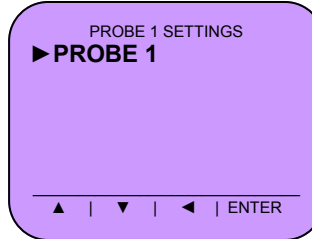

Analog Inputs

Use ▲ and ▼ to highlight the analog input you wish to change, then press ENTER.

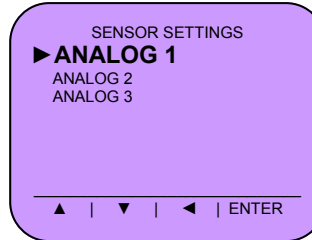

Analog Name

This setting allows you to change the name of each analog input independently. You have a maximum of 12 characters. Use ▲ and ▼ to change the letters of the input, then press ENTER.

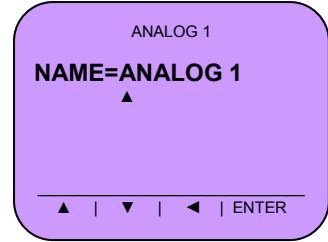
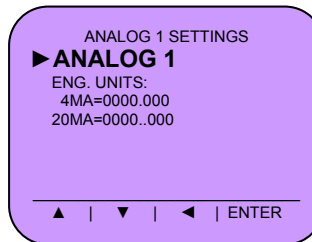

Engineering Units

If using an analog sensor, you can specify what units that the device measures (pH for example). Use ▲ and ▼ to change the letters of the engineering units, then press ENTER.

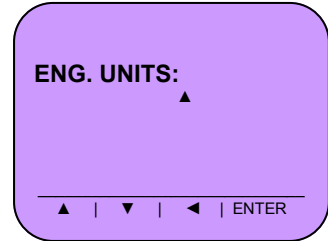
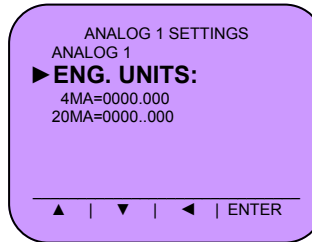

4mA

To change the 4mA setting use the ▶ and ◀ keys to move the cursor (▲) to the number you want to change. Use the ▲ key to change the number. Once you have reached the last number press the ▶ key one more time to save and exit back to the settings menu. Use the EXIT key to exit without saving.

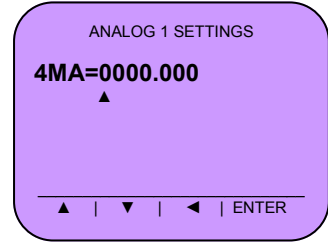
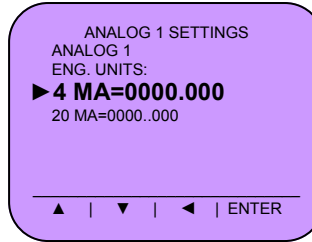

20mA

To change the 20 mA setting use the ▶ and ◀ keys to move the cursor (▲) to the number you want to change. Use the ▲ key to change the number. Once you have reached the last number press the ▶ key one more time to save and exit back to the settings menu. Use the EXIT key to exit without saving.

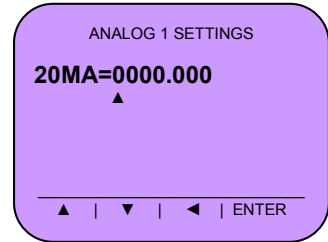
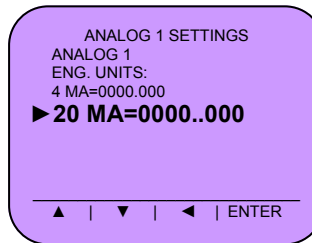

PUMP SETTINGS MENU

Use the ▲ and ▼ key to highlight PUMP SETTINGS, then press ENTER.

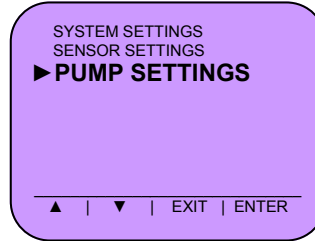

Prime Pumps

Use the ▲ and ▼ keys to highlight the pump you want to prime. Press the ENTER key.

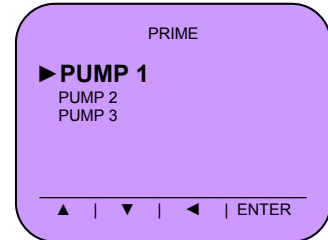
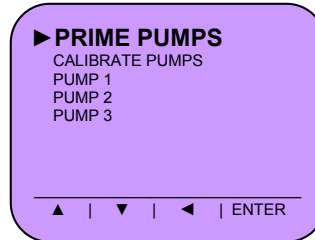

Use the keys directly below the START to turn the pump on and begin priming. When fully primed use the key directly below the STOP to turn the pump off. Repeat as necessary for other pumps.

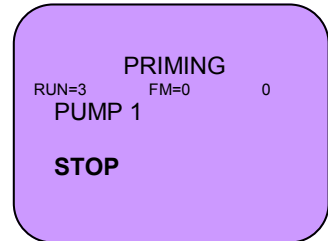
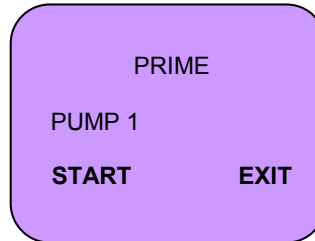

Calibrate Pumps

To calibrate the pumps use the keys directly below the pump you wish to calibrate to select.

Press the key directly below “START” to turn the pump on. Allow to run for at least 10 seconds while capturing output in measurement vessel. Press the key directly below “STOP” to turn the pump off. Once complete it will advance to the next screen.

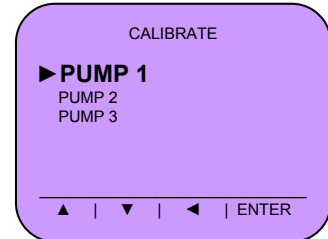
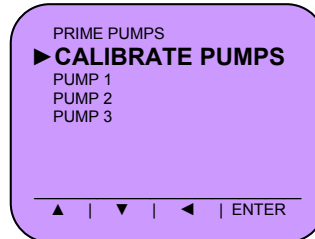

NOTE: you have a maximum pump calibration ON time of 2 minutes.

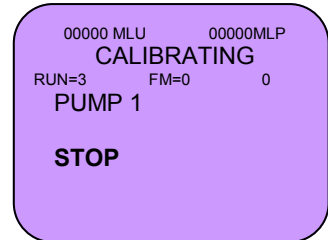
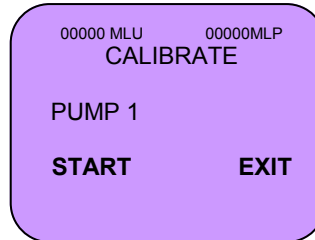

To enter the volume dispensed use the ENTER key to move the cursor (▲) to the number you want to change. Use the ▲ and ▼ keys to change the number. Once you have reached the last number press the ENTER key one more time to save and exit back to the settings menu. Use the MENU key to exit without saving. Repeat for other pumps.

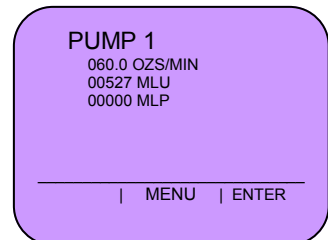
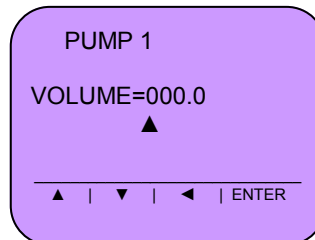

Pump Settings

Use the ▲ and ▼ highlight the pump you wish to change, then press ENTER.

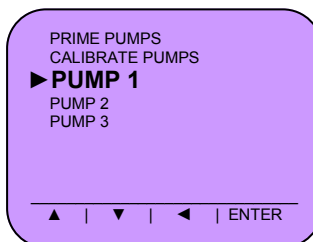

Pump Name

To change pump names use the ENTER key to move the cursor (▲) to the letter you want to change. Use the ▲ and ▼ keys to change the letter. Once you have reached the last letter press the ENTER key one more time to save and exit back to the settings menu. Use the MENU key to exit without saving.

NOTE: You have a maximum of 12 characters for each chemical name.

Pump Mode

None is the default value and must be changed to one of the four available modes for the pump to operate.

- Relay
- Signal
- Repeat Cycle
- Probe

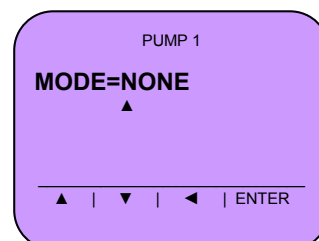
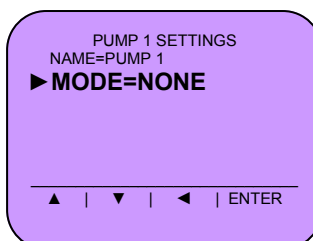
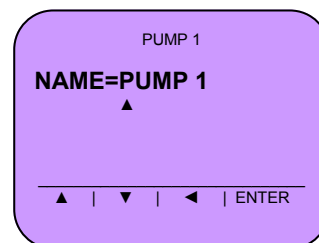
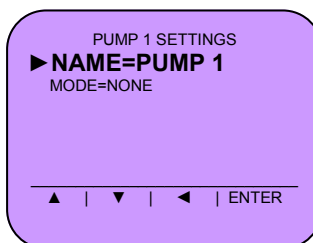

Relay Mode

Use the ▲ and ▼ key to highlight RELAY, then press ENTER.

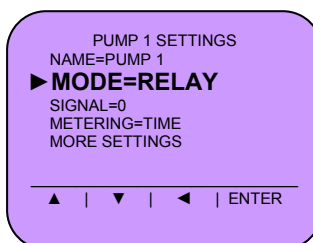

Signal

This setting tells the system which of the available signal inputs will be used to activate the pump.

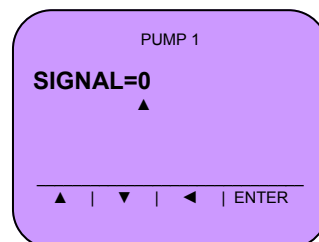
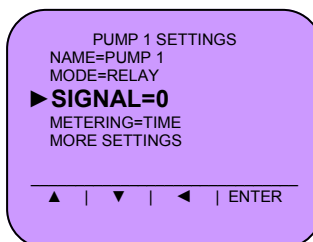

Metering

This setting is used to select between time or flow meter based metering of the chemicals. When time is selected, the system will run the pumps based on the flow rate calibrated for a specific amount of time. When flow meter is selected, the pump delivery will be monitored by the flow meter to ensure that the correct amount of chemical is dispensed.

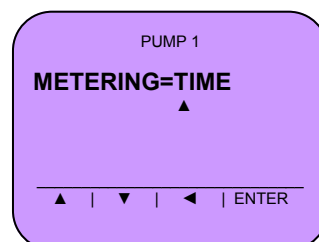
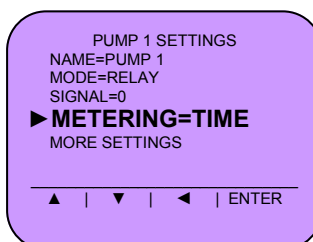

DC Speed

This setting allows you to control the speed of the pump to match the requirements of the application.

NOTE: This is only for the cover mounted peristaltic pumps.

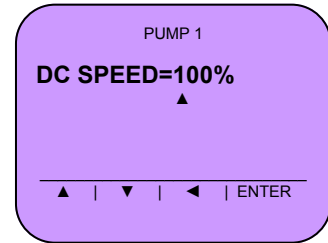
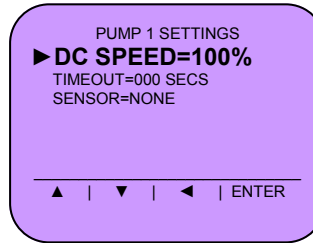

Timeout

To change the timeout setting use the ▶ and ◀ keys to move the cursor (▲) to the number you want to change. Use the ▲ key to change the number. Once you have reached the last number press the ▶ key one more time to save and exit back to the settings menu. Use the EXIT key to exit without saving.

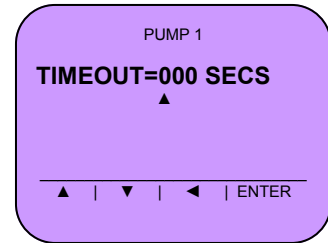
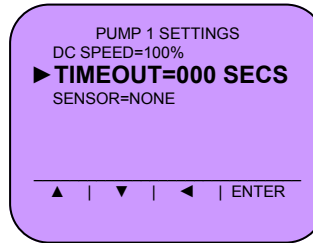

Sensor

This setting tells the system which of the available sensor inputs will be used with the pump.

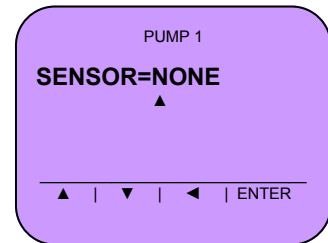
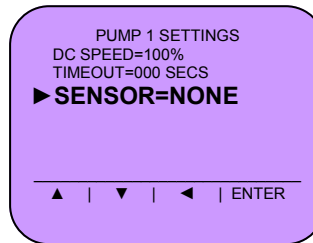

Signal Mode

This mode of operation runs the pump to deliver a single dosage of chemical when triggered by an input signal.

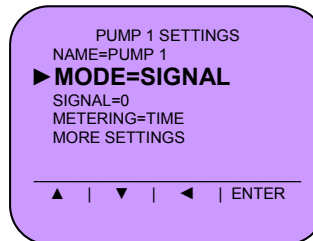

Signal

This setting tells the system which of the available signal inputs will be used to activate the pump.

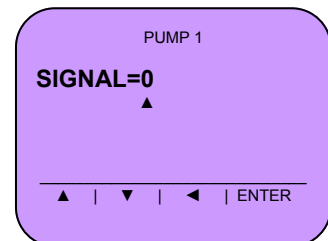
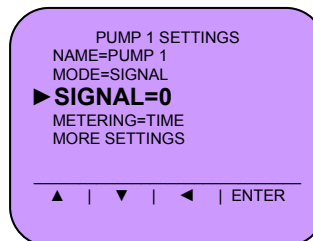

Metering

This setting is used to select between time or flow meter based metering of the chemicals. When time is selected, the system will run the pumps based on the flow rate calibrated for a specific amount of time. When flow meter is selected, the pump delivery will be monitored by the flow meter to ensure that the correct amount of chemical is dispensed.

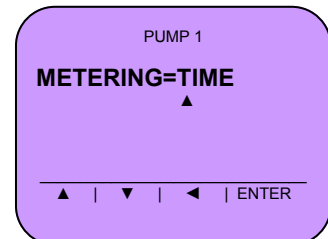
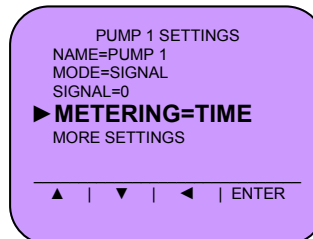

DC Speed

This setting allows you to control the speed of the pump to match the requirements of the application.

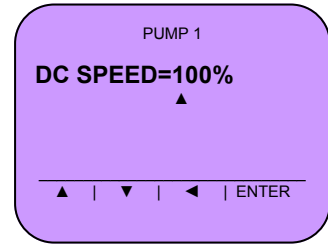
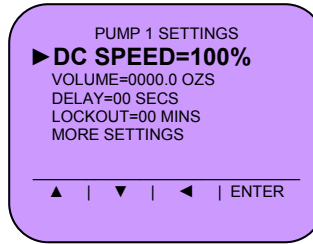

Volume

To change the volume setting use the ▶ and ◀ keys to move the cursor (▲) to the number you want to change. Use the ▲ key to change the number. Once you have reached the last number press the ▶ key one more time to save and exit back to the settings menu. Use the EXIT key to exit without saving.

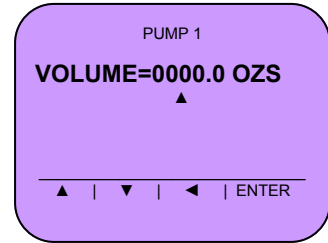
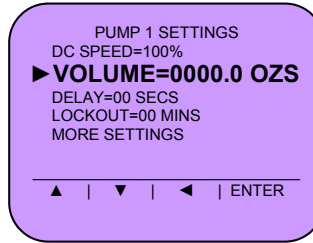

Delay

To change the delay setting use the ▶ and ◀ keys to move the cursor (▲) to the number you want to change. Use the ▲ key to change the number. Once you have reached the last number press the ▶ key one more time to save and exit back to the settings menu. Use the EXIT key to exit without saving.

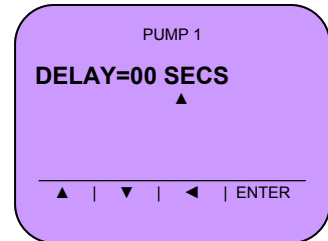
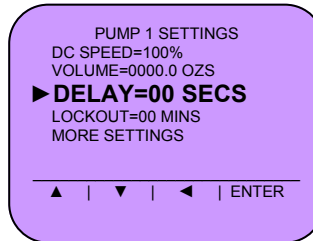

Lockout

To change the lockout setting use the ▶ and ◀ keys to move the cursor (▲) to the number you want to change. Use the ▲ key to change the number. Once you have reached the last number press the ▶ key one more time to save and exit back to the settings menu. Use the EXIT key to exit without saving.

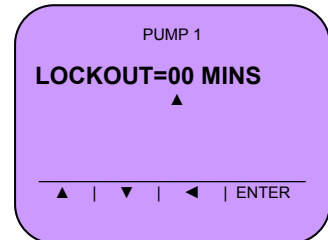
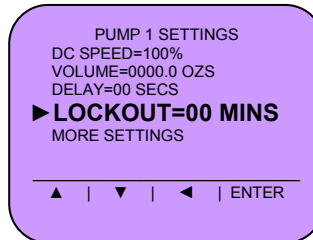

Sensor

This setting tells the system which of the available sensor inputs will be used with the pump.

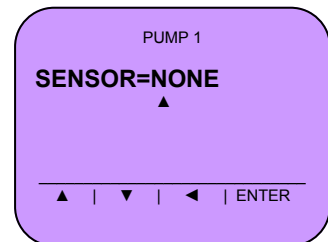
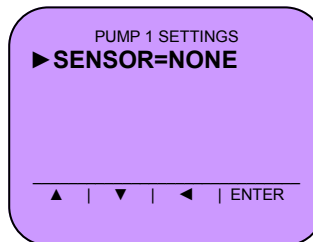

Repeat Cycle Mode

Use the ▲ and ▼ key to highlight REPEAT CYCLE, then press ENTER.

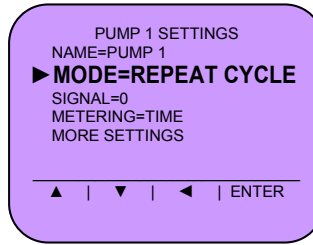

Signal

This setting tells the system which of the available signal inputs will be used to activate the pump.

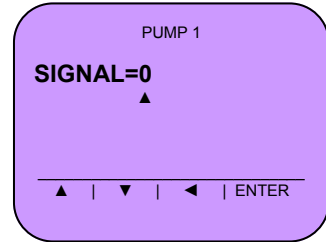
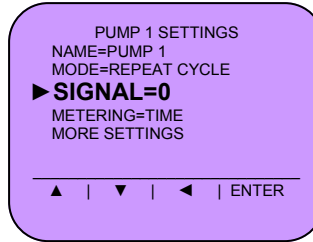

Metering

This setting is used to select between time or flow meter based metering of the chemicals. When time is selected, the system will run the pumps based on the flow rate calibrated for a specific amount of time. When flow meter is selected, the pump delivery will be monitored by the flow meter to ensure that the correct amount of chemical is dispensed.

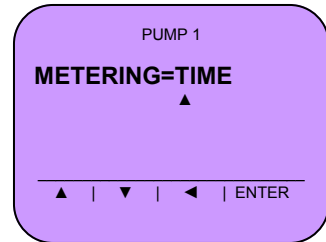
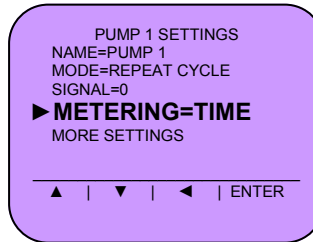

DC Speed

This setting allows you to control the speed of the pump to match the requirements of the application.

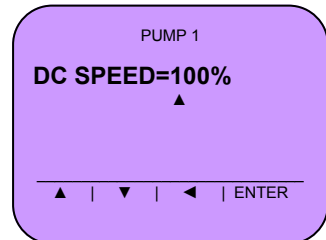
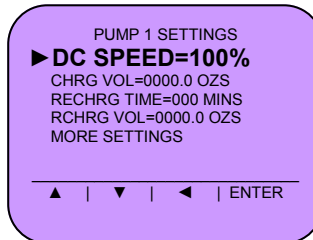

Charge Volume

With CHARGE VOL selected, press the ENTER key. To change the charge volume setting use the ► and ◀ keys to move the cursor (▲) to the number you want to change. Use the key to change the number. Once you have reached the last number press the ► key one more time to save and exit back to the settings menu. Use the EXIT key to exit without saving.

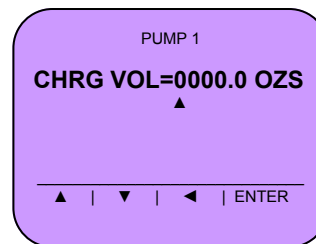
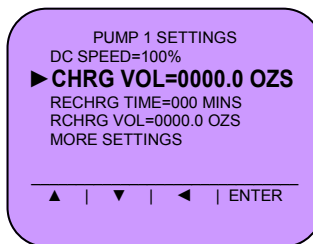

Recharge Time

To change the recharge time use the ► and ◀ keys to move the cursor (▲) to the number you want to change. Use the ▲ key to change the number. Once you have reached the last number press the ► key one more time to save and exit back to the settings menu. Use the EXIT key to exit without saving.

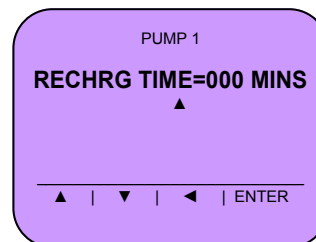
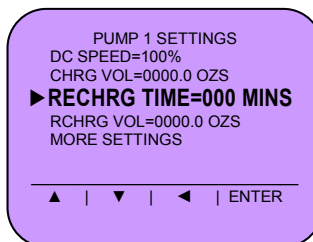

Recharge Volume

With RECHARGE VOL selected press the ENTER key. To change the recharge setting use the ► and ◀ keys to move the cursor (▲) to the number you want to change. Use the ▲ key to change the number. Once you have reached the last number press the ► key one more time to save and exit back to the settings menu. Use the EXIT key to exit without saving.

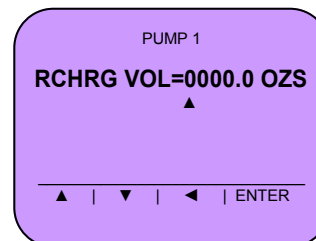
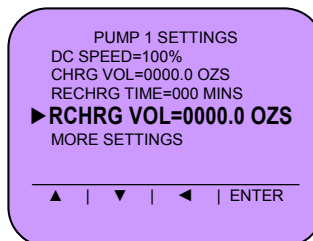

NOTE: Each pump can have independent recharge settings for each chemical.

Reset Delay

This setting allows the signal to turn off for a specified time and continue normal operation if the signal turns back on within this timeframe. If the signal turns off for longer than this setting, then the system will re-start the operation cycle with a new initial charge and ongoing recharges.

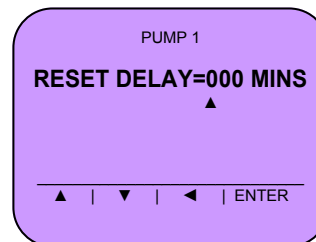
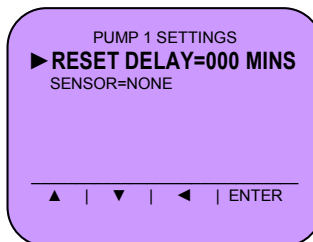

Sensor

This setting tells the system which of the available sensor inputs will be used with the pump.

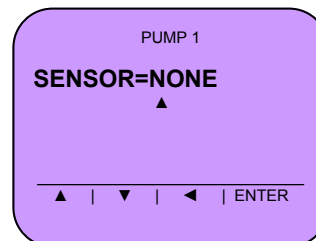
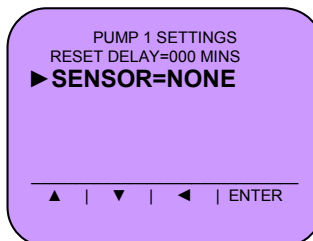

Probe Mode

Use the ▲ and ▼ key to highlight PROBE, then press ENTER.

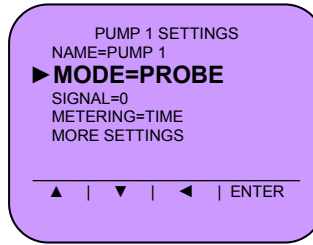

Signal

This setting tells the system which of the available signal inputs will be used to activate the pump.

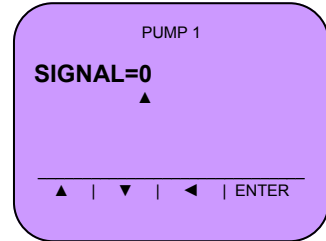
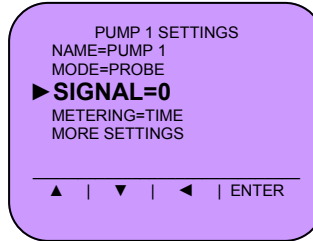

Metering

This setting is used to select between time or flow meter based metering of the chemicals. When time is selected, the system will run the pumps based on the flow rate calibrated for a specific amount of time. When flow meter is selected, the pump delivery will be monitored by the flow meter to ensure that the correct amount of chemical is dispensed.

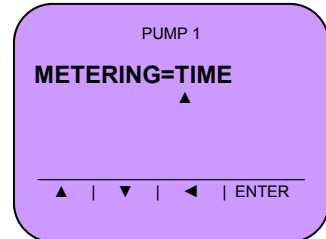
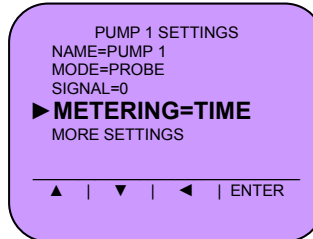

DC Speed

This setting allows you to control the speed of the pump to match the requirements of the application.

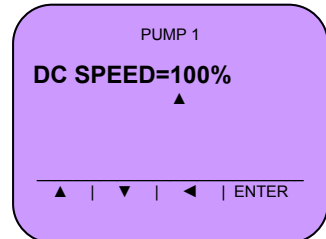
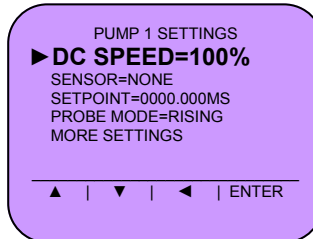

Sensor

This setting tells the system which of the available sensor inputs will be used with the pump.

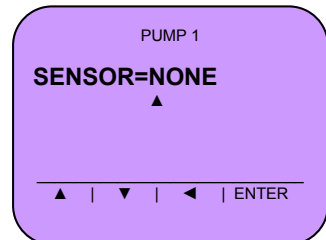
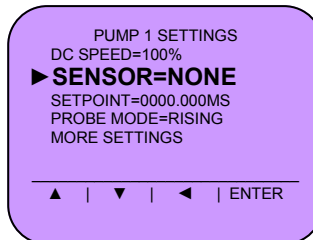

Setpoint

To change the concentration setpoint use the ► and ◀ keys to move the cursor (▲) to the number you want to change. Use the ▲ key to change the number. Once you have reached the last number press the ► key one more time to save and exit back to the settings menu. Use the EXIT key to exit without saving.

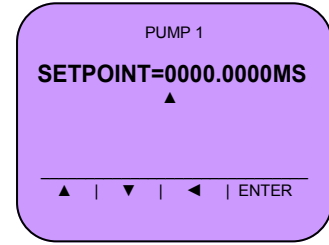
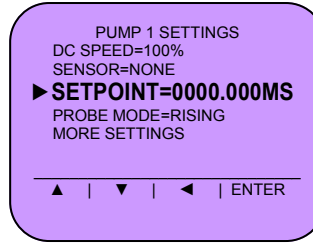

Probe Mode

Sets the pump to turn on so that it will either “Rise” up to the setpoint (then turn off) or turn on to “Fall” down to the setpoint (then turn off).

Use the key directly below RISING or below FALLING to make your choice. Then press ENTER to continue.

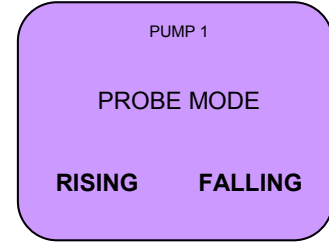
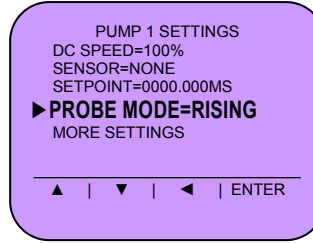

Alarm Delay

To change the alarm delay use the ► and ◀ keys to move the cursor (▲) to the number you want to change. Use the ▲ key to change the number. Once you have reached the last number press the ► key one more time to save and exit back to the settings menu. Use the EXIT key to exit without saving.

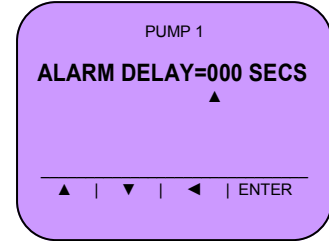
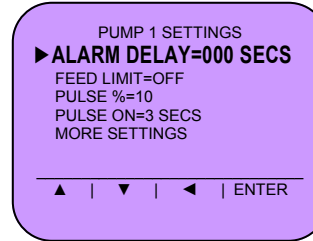

Feed Limit

Use the key directly below ON to turn the feature on (or below OFF to turn the feature off). Then press ENTER to continue.

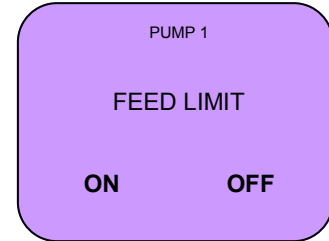
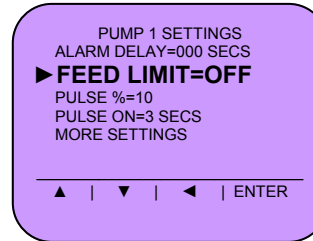

Pulse %

This setting tells the system when to begin pulse feeding; specifically at what percent of the setpoint you have established.

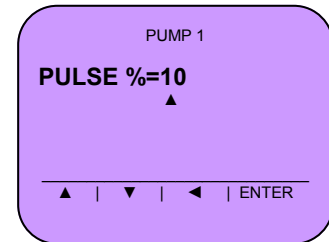
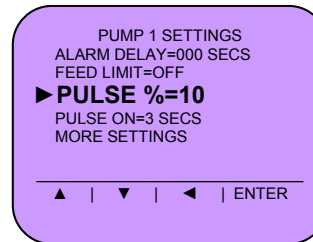

Pulse On

This setting controls how long the pump will be ON during the pulse feed stage of operation.

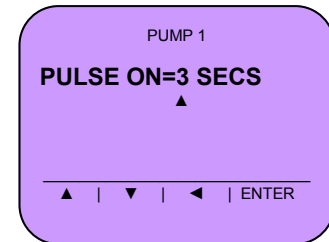
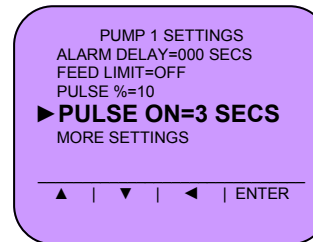

Pulse Off

This setting controls how long the pump will be OFF during the pulse feed stage of operation.

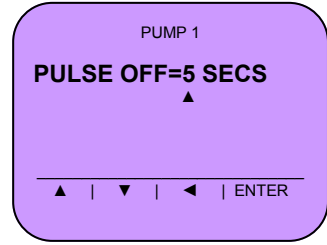
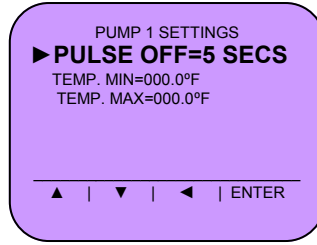

Temp Min

Specify the minimum operating temperature. If the temperature falls below this value, a warning will be displayed on the front panel and the error will be recorded into the report memory.

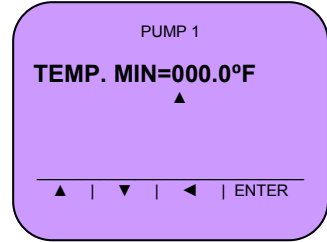
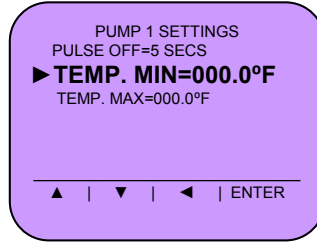

Temp Max

Specify the maximum operating temperature. If the temperature rises above this value, a warning will be displayed on the front panel and the error will be recorded into the report memory.

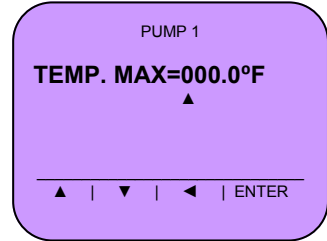
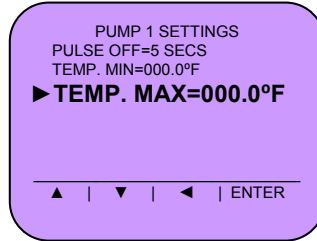

DIAGNOSTICS

Use the ▲ and ▼ key to highlight DIAGNOSTICS, then press ENTER.

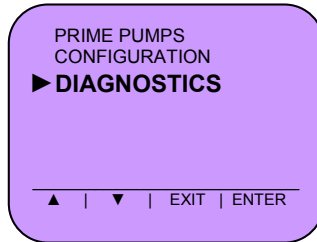

Use the ▲ and ▼ key to browse through the four diagnostic display screens listed below.

- Signal Inputs
- Low Level Inputs
- Probe Readings
- Analog Readings

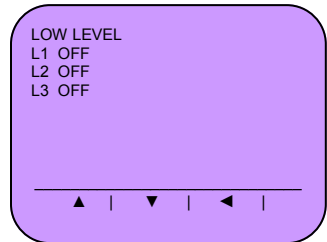
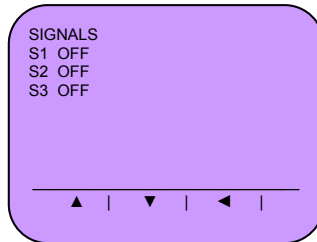

When finished, press the ◀ key to return to normal pump operation.

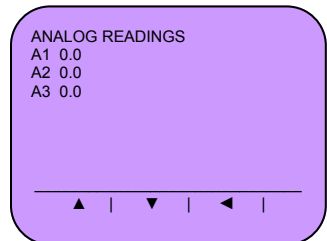
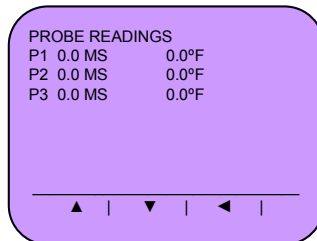

OPERATION ERROR SCREENS

Missing Calibration Error

If any of the pumps are not calibrated prior to operation you will get a "CALIBRATE PUMP" error screen in red showing which pump is missing the calibration. Press any key to continue. Go into the main menu and calibrate pumps.

PUMP NAME
CALIBRATE PUMP

Flow Meter Error

The screen will show which pump has a flow meter error. You can disable the flow meter to allow the pump to operate in time mode while the problem is being rectified.

PUMP NAME
FLOW METER ERROR

DISABLE FLOW ME-
TER?

Probe Error

This display indicates that one of the probes connect-
ed to the system is not recognized. Check wiring from
the probe to the main control board.

PROBE ERROR

Low Level Error

When a chemical container is low (or empty) this
message will indicate which pump is affected.

LOW LEVEL

Temperature Error

This display will show if the temperature is out of
range (low or high) for any chemical that temperature
monitoring is enabled.

TEMPERATURE

I/O Communication Error

If the I/O board is not detected during advanced sys-
tem operation you will get an "I/O COMMUNICATION
ERROR" screen in red.

I/O COMMUNICATION
ERROR

PC APPLICATION

The Control Guard ACCS can be programmed using the front panel on the machine or by programming a system setup file using the PC software application and uploading the settings to the machine using a USB device. The preferred method is to use the pc software tool as it will save time and allow you to use previously programmed files saved on your computer.

Control Guard ACCS PC Software for Windows

This simple PC application tool is designed to help you manage your Control Guard ACCS system files. A laptop computer with a USB port must be used for programming units in the field.

Installing the Control Guard ACCS PC Software:

- (1) Before installing you need to download drivers from the Microsoft Download website. Once on the site use the search function to find Microsoft .NET Framework 3.5 Service Pack 1. Download and install these system files as instructed.
- (2) After downloading the drivers from Microsoft, download the Control Guard ACCS application from the following link: <http://knight.idexftp.com> The Login ID is CG ACCS and the Password is Knight FCS. These are case sensitive.
- (3) After downloading the PC application file, follow the installation prompts. The program icon will automatically be placed on your desktop at the end of the installation.
- (4) Double click the Control Guard icon to start the application.



Creating a Location and Setup File

All setup and report files are archived based on the location of each of the systems you install. If you have multiple units at one installation site, it's best to keep all of the report files under a single name location. For new installations create a new location by doing the following:

- (1) Click "Edit Locations" button.

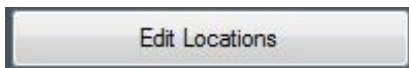

- (2) Click "New" button and enter a name for the installation site. Click "Save" when done. Click "OK".

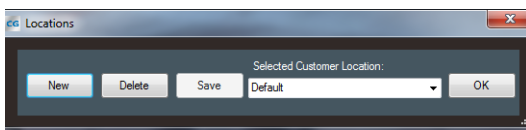

- (3) Click "Program New System File" button.

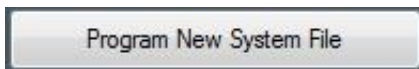

System Settings Screen

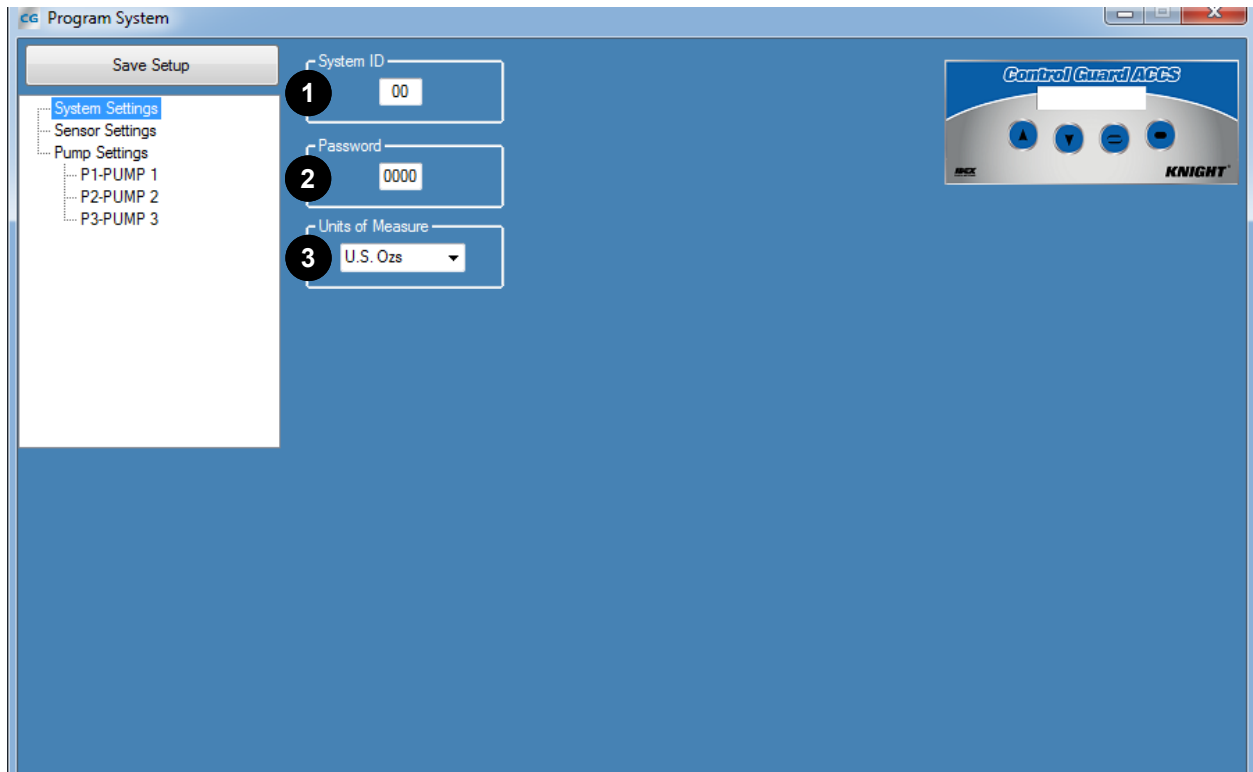

- (1) System ID: – The system ID will be used to manage each specific system on each site with varying system run parameters. When downloading a setup file to the machine from a USB drive you must have the system ID in the machine set to the matching system ID from the PC application setup file created. You can have up to 100 (00 thru 99) system IDs for each location.
- (2) Password: – This is the password you will use to access all of the programming menus on the Control Guard ACCS front panel. It allows access to all programming functions. Each system is shipped from the factory with 0000 as the access code. Do not leave “0000” as the code as this may allow unwanted access to your settings and can disrupt normal operation of the system by unauthorized personnel.
- (3) Units: – Selecting U.S. ozs, users see fluid measurements in U.S. ounces and temperature settings in degrees F. Use Metric for fluid measurements in milliliters and temperature settings in degrees C. This setting also defines how the system will track chemical usage and temperature readings for reporting purposes.

Sensor Settings Screen

- (4) Inductive Probes: Each probe can have its own unique name. You have a maximum of 12 characters.
- (5) Analog Inputs:
- Name: Each analog input can have its own unique name. You have a maximum of 12 characters.
 - Eng Units: Specify the Engineering units that each analog device will measure.
 - 4mA: Specify the lowest value that each analog input will measure.
 - 20mA: Specify the highest value that each analog input will measure.

Pump Settings Screen (shown on next page)

- (6) Name: Pump 1 is the first pump on the left in the main cabinet (pumps 2 and 3 are to the right respectively). Use this field to change the pump names if desired. You have a maximum of 12 characters.
- Mode: There are 4 operating modes available in the Control Guard ACCS as follows: Relay Mode, Signal Mode, Repeat Cycle Mode and Probe Mode. Each pump can have its own individual setting to allow the system to cover a wide range of applications.
- Signal: Choose the signal input that will be used to activate each pump. Note that more than one pump can “share” a signal when applicable to reduce the number of electrical wiring connections.
- DC Speed: Controls the speed of each pump individually based on your specific delivery requirements.
- Sensor: Specify which sensor that each pump will use (if applicable).
- Metering: Choose time or flow meter based delivery of the chemicals. When time is selected, the system will run the pumps based on the flow rate calibrated for a specific amount of time. When flow meter is selected, the pump delivery will be monitored to ensure that the correct amount of chemical is dispensed.
- Temp Min: Specify the minimum operating temperature. If the temperature falls below this value, a warning will be displayed on the front panel and the error will be recorded into the report memory.
- Temp Max: Specify the maximum operating temperature. If the temperature rises above this value, a warning will be displayed on the front panel and the error will be recorded into the report memory.
- (7) Relay Mode: This mode of operation allows the pump to run for as long as the input signal is present.
- Timeout: The amount of idle time before the chemical dosage is logged into memory for reporting purposes.

Pump Settings Screen

- (8) **Signal Mode:** This mode runs the pump to deliver a single dosage of chemical when triggered by an input signal.
Volume: The amount of chemical that will be dispensed.
Delay (secs): – The delay time is the time that the system will delay the start of the pump activation after the input signal has been applied. Use this setting if you require additional time between signal activation and pump startup. You have a maximum of 999 seconds.
Lockout: How long the pump will ignore the input signal to prevent accidental dosage.
- (9) **Repeat Cycle Mode:** Runs the pump for an initial charge feed, then cycles a recharge amount that is timed.
Charge Volume: The amount of chemical that is dispensed upon application of the signal.
Recharge Time: The interval between initial charge and recharge. Continues as long as signal is present.
Recharge Volume: The amount of chemical that is repeated for the recharge time interval.
Reset Delay: Sets the amount of time that the signal can turn off without restarting the entire cycle over.
- (10) **Probe Mode:** Utilizes a probe to sense and maintain a specific chemical solution strength.
Setpoint: The numeric value that represents the chemical concentration you wish to maintain.
Mode: Sets the pump to turn on so that it will either “Rise” up to the setpoint (then turn off) or turn on to “Fall” down to the setpoint (then turn off).
Alarm Delay: The timeframe before the alarm sounds.
Feed Limit: Stops the pump from running when the alarm has sounded.
Pulse %: Sets the pulse feed to begin at a specific percentage of the setpoint value.
Pulse On Time: How long the pump will run when pulse feeding.
Pulse Off Time: How long the pump will be off when pulse feeding.
- (11) **Calibration:** This function will show as darkened (cannot change settings). The numbers will be zero for a new setup file and will only show data if the file was downloaded from an actual pump system.
Flow Rate: The speed at which chemical is moved through the pump (also referred to as calibration).
MLU: For Knight technical reference.
MLP: For Knight technical reference.
- (12) **Save Setup:** Once you have filled in all of your operation parameters, click this button to save.

Copying Setup Files from PC to USB device

Once you have completed all of your system settings and saved them to the PC application, you are now ready to transfer the setup file to the system.

- (1) Insert your USB device into your computer.
- (2) Click on “Copy Setup to USB Drive” from the PC application home page.

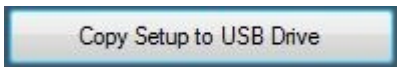

- (3) Select the drive letter for your USB device.

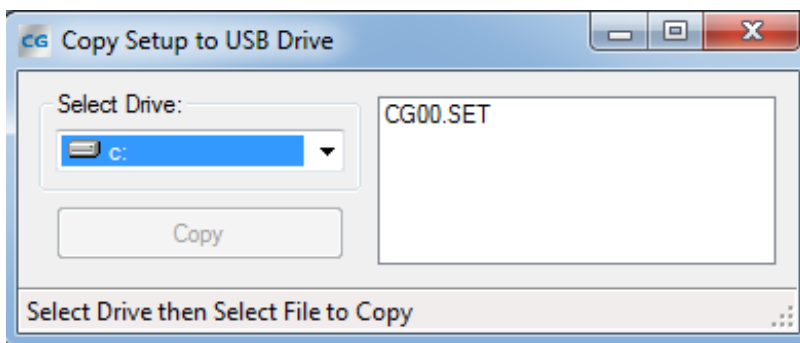

- (4) Select the file you want to save to the USB device and click “Copy”.

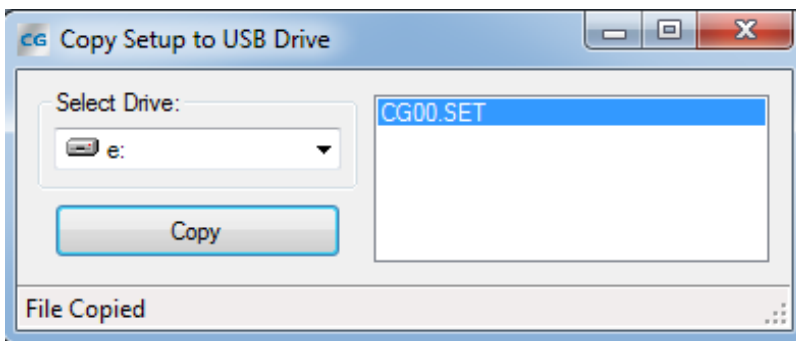

- (5) The bottom of the screen will say “File Copied”. The file has now been saved and is ready to be installed on the machine.

Copying Files from USB device to PC

Once you have saved setup and/or report files from your system you are now ready to upload the files to your PC application.

- (1) Insert your USB device into your computer.
- (2) Click on "Copy Files from USB Drive" from the PC application home page.

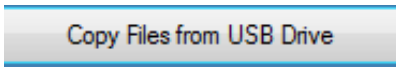

- (3) Select the drive letter for your USB device.

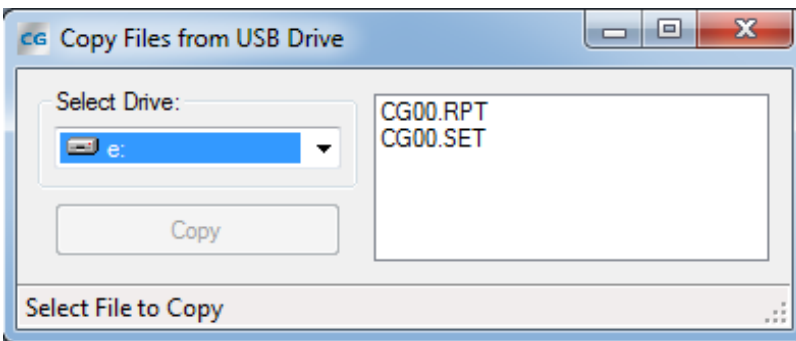

- (4) Select the file you want to save to the PC application and click "Copy".

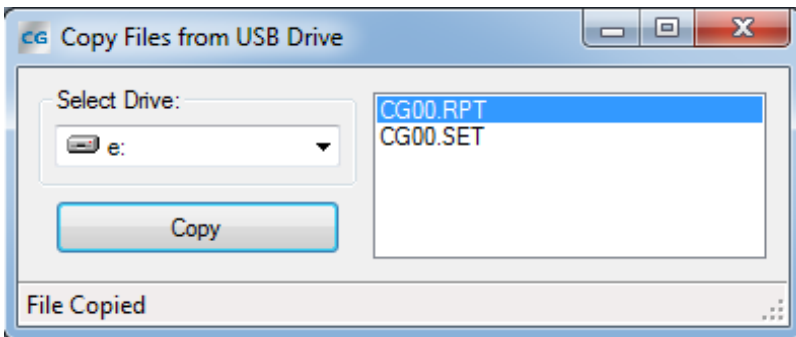

- (5) The bottom of the screen will say "File Copied". The file has now been saved and can be viewed and edited with the PC application.

Setup Report

The setup report shows all programmed settings for each pump that is used. Use this report to verify all of the system settings in a single view. You can also confirm that the settings are correct for your application.

	A	B	C	D	E	F	G	H	I	J	K									
1	 1			Report Created:	Report Dates: (From - To)															
2				03/29/2016 11:45	02/01/2016	03/31/2016														
3																				
4				System ID:	10															
5				Units:	U.S. OZS															
6																				
7	Setup Report																			
8	PUMP 1			PUMP 2			PUMP 3			Probe 1										
9	Mode:	Relay		Mode:	None		Mode:	None		Name:	PROBE 1									
10	Signal:	2		Signal:	2		Signal:	0		Probe 2										
11	Metering:	Time		Metering:	Time		Metering:	Time												
12	DC Speed:	50%		DC Speed:	20%		DC Speed:	100%		Name:	PROBE 2									
13	Sensor:	ANALOG 1		Sensor:	None		Sensor:	None		Probe 3										
14	Temperature Min:	0.0 °F		Temperature Min:	0.0 °F		Temperature Min:	0.0 °F												
15	Temperature Max:	0.0 °F		Temperature Max:	0.0 °F		Temperature Max:	0.0 °F		Name:	PROBE 3									
16	Relay Mode			Relay Mode			Relay Mode			Analog 1										
17	Timeout:	20 secs		Timeout:	0 secs		Timeout:	0 secs		Name:	ANALOG 1									
18	Signal Mode			Signal Mode			Signal Mode			Eng Units:	mS									
19										Volume:	50.0 ozs		Volume:	300.0 ozs		Volume:	50.0 ozs		4ma:	0.000
20										Delay:	0 secs		Delay:	5 secs		Delay:	10 secs		20ma:	200.000
21	Lockout:	0 mins		Lockout:	0 mins		Lockout:	0 mins		Analog 2										
22	Repeat Cycle Mode			Repeat Cycle Mode			Repeat Cycle Mode													
23	Charge Volume:	300.0 ozs		Charge Volume:	300.0 ozs		Charge Volume:	300.0 ozs				Name:	ANALOG 2							
24	Recharge Time:	10 mins		Recharge Time:	10 mins		Recharge Time:	10 mins		Eng Units:	mS									
25	Recharge Volume:	300.0 ozs		Recharge Volume:	300.0 ozs		Recharge Volume:	300.0 ozs		4ma:	0.000									
26	Reset Delay:	0 mins		Reset Delay:	0 mins		Reset Delay:	0 mins		20ma:	0.000									
27	Probe Mode			Probe Mode			Probe Mode			Analog 3										
28										Setpoint:	20.000mS		Setpoint:	0.000		Setpoint:	0.000		Name:	ANALOG 3
29										Mode:	Falling		Mode:	Rising		Mode:	Rising		Eng Units:	mS
30										Alarm Delay:	30 secs		Alarm Delay:	0 secs		Alarm Delay:	0 secs		4ma:	0.000
31										Feed Limit:	On		Feed Limit:	On		Feed Limit:	On		20ma:	0.000
32										Pulse:	50%		Pulse:	10%		Pulse:	10%			
33	Pulse On:	3 secs		Pulse On:	3 secs		Pulse On:	3 secs												
34	Pulse Off:	5 secs		Pulse Off:	5 secs		Pulse Off:	5 secs												

- (1) Report Header: Shows the date report was created, what time period is covered, system ID number and units.
- (2) Pump Info: This is the section that shows how each pump is setup for operation.
- (3) Inductive Probes: Shows probe names.
- (4) Analog Probes: Shows names, Engineering units, and programmed values for 4mA and 20mA reference points.

Summary Reports

This report provides a summary of chemical usage for each pump. The information provided can be used for many uses such as inventory tracking, cost and billing, or consumption due to various field conditions.

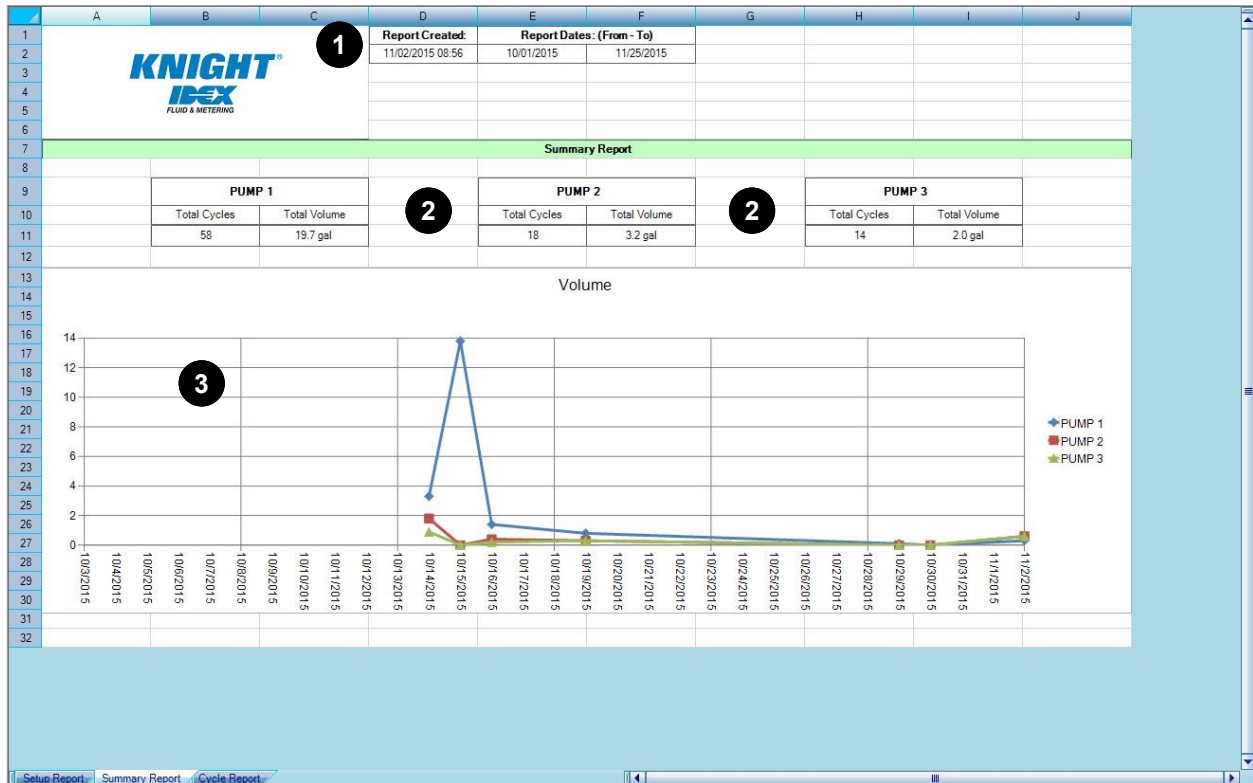

- (1) Report Header: Shows the date report was created, and what time period is covered.
- (2) Pump Info: Shows the total cycles and volume used for each pump.
- (3) Graph: Provided as a visual aid to analyze chemical consumption by each pump in a timeline format.

Cycle Report

This report shows tracking of chemical usage and temperature readings by individual pump. The information is tracked by date and time and also shows any error messages tracked which allows this report to be a helpful tool in diagnosing any operational problems.

A		B		C		D		E		F		G		H		I		J		K		L	
				Report Created: 11/02/2015 08:56				Report Dates: (From - To) 10/01/2015 11/25/2015															
Cycle Report																							
Start Date	Start Time	End Date	End Time	Error	Pump	Volume	Sensor	Sensor Minimum Reading	Sensor Maximum Reading	Temperature Minimum Reading	Temperature Maximum Reading												
10/16/2015	11:27			Power Cycle																			
10/16/2015	11:30			Power Cycle																			
10/16/2015	11:43			Power Cycle																			
10/16/2015	12:22			Power Cycle																			
10/16/2015	12:27	10/16/2015	12:28		PUMP 3	28.0 ozs																	
10/16/2015	12:27	10/16/2015	12:29		PUMP 2	54.3 ozs																	
10/16/2015	12:27	10/16/2015	12:30		PUMP 1	127.1 ozs	CIP 1	23.025mS	23.047mS	79.8 °F	80.0 °F												
10/16/2015	12:32			Power Cycle																			
10/16/2015	12:33	10/16/2015	12:34		PUMP 1	43.0 ozs	CIP 1	8.494mS	52.682mS	80.2 °F	80.2 °F												
10/16/2015	12:44			Temperature Low Alarm	PUMP 1																		
10/16/2015	12:44	10/16/2015	12:45		PUMP 1	12.6 ozs	CIP 1	6.299mS	65.535mS	80.7 °F	80.7 °F												
10/19/2015	05:17	10/19/2015	05:18		PUMP 1	4.5 ozs	CIP 1	11.913mS	65.535mS	77.9 °F	77.9 °F												
10/19/2015	05:39			Power Cycle																			
10/19/2015	07:22			Power Cycle																			
10/19/2015	12:26			Power Cycle																			
10/19/2015	12:36	10/19/2015	12:37		PUMP 1	61.6 ozs	CIP 1	6.990mS	29.092mS	78.4 °F	78.4 °F												
10/19/2015	12:52	10/19/2015	12:52		PUMP 3	9.5 ozs																	
10/19/2015	12:52	10/19/2015	12:52		PUMP 2	17.1 ozs																	
10/19/2015	12:52	10/19/2015	12:52		PUMP 1	11.2 ozs	CIP 1	6.708mS	65.535mS	26.0 °F	26.0 °F												
10/19/2015	12:55			Flow Meter Error	PUMP 1																		
10/19/2015	12:55	10/19/2015	12:55		PUMP 1	13.0 ozs	CIP 1	20.161mS	20.164mS	78.9 °F	78.9 °F												
10/19/2015	12:55	10/19/2015	12:56		PUMP 3	28.0 ozs																	
10/19/2015	12:55	10/19/2015	12:56		PUMP 2	21.2 ozs																	
10/19/2015	12:57			Temperature Low Alarm	PUMP 1																		
10/19/2015	12:57	10/19/2015	12:58		PUMP 1	11.0 ozs	CIP 1	5.790mS	65.535mS	78.9 °F	78.9 °F												
10/20/2015	06:55			Power Cycle																			
10/20/2015	08:59			Power Cycle																			
10/20/2015	09:01			Power Cycle																			
10/21/2015	05:05			Power Cycle																			

- Report Header: Shows the date report was created, and what time period is covered.
- Cycle Start/End: Shows the starting and ending time stamp by date for each cycle logged..
- Cycle Errors: Use this column to monitor and troubleshoot any error conditions that may have occurred.
- Pump Info: This section shows the pump name, volume logged and sensor used for this pump.
- Readings: This section shows the logged minimum and maximum readings for the sensor and temperature.

Exporting to Excel Format

Anytime a report is open for viewing you can choose to save the file in an Excel format by simply clicking on the "Save to Excel File" button located in the upper left of the report viewer. The Excel version of the report appears in the System Files directory in the column marked Excel Reports. Provided you have Excel 2007 or newer you can then email these files, merge them with older records or manipulate the data in any way that suits your needs.

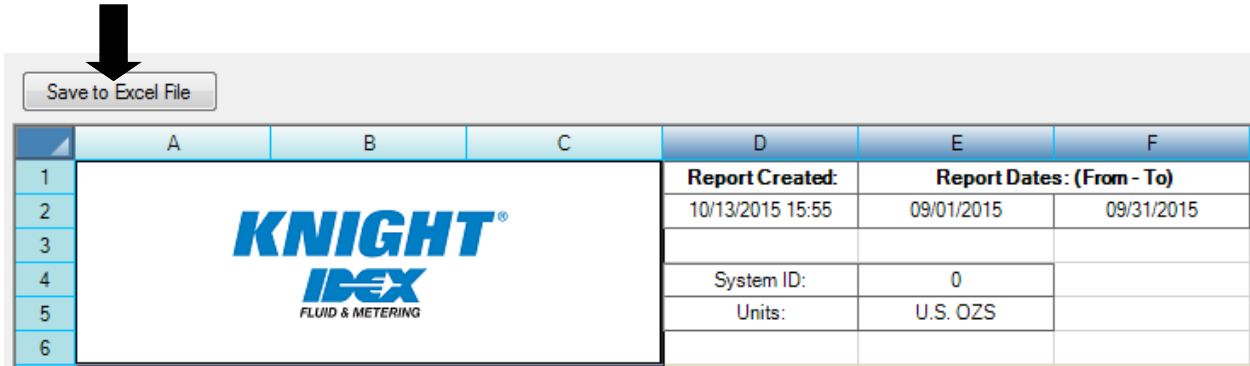

A black arrow points to a button labeled "Save to Excel File". Below the button is a screenshot of an Excel spreadsheet. The spreadsheet has columns A through F and rows 1 through 6. The logo for "KNIGHT IDEX FLUID & METERING" is centered in the first three columns. The right side of the spreadsheet contains report metadata:

Report Created:	Report Dates: (From - To)	
10/13/2015 15:55	09/01/2015	09/31/2015
System ID:	0	
Units:	U.S. OZS	

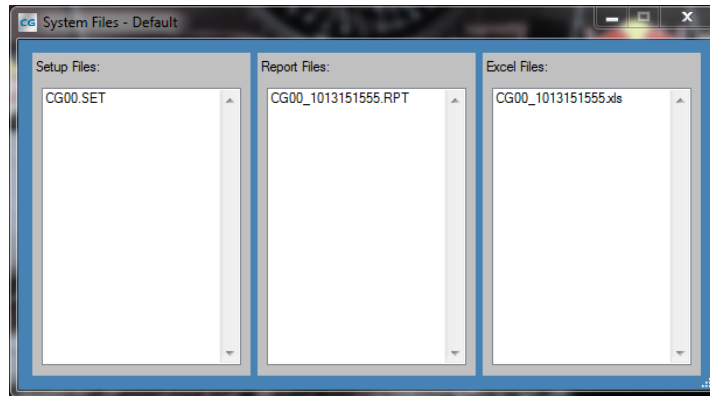

SYSTEM DIMENSIONS

Main Cabinet (all models)

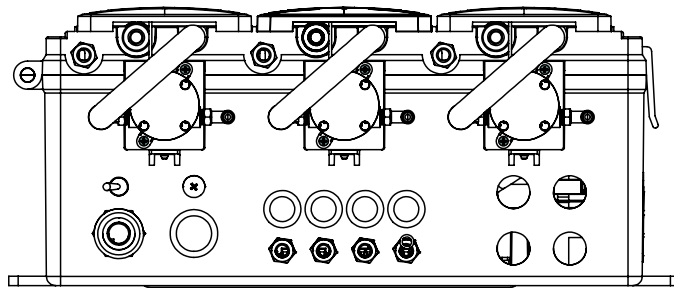
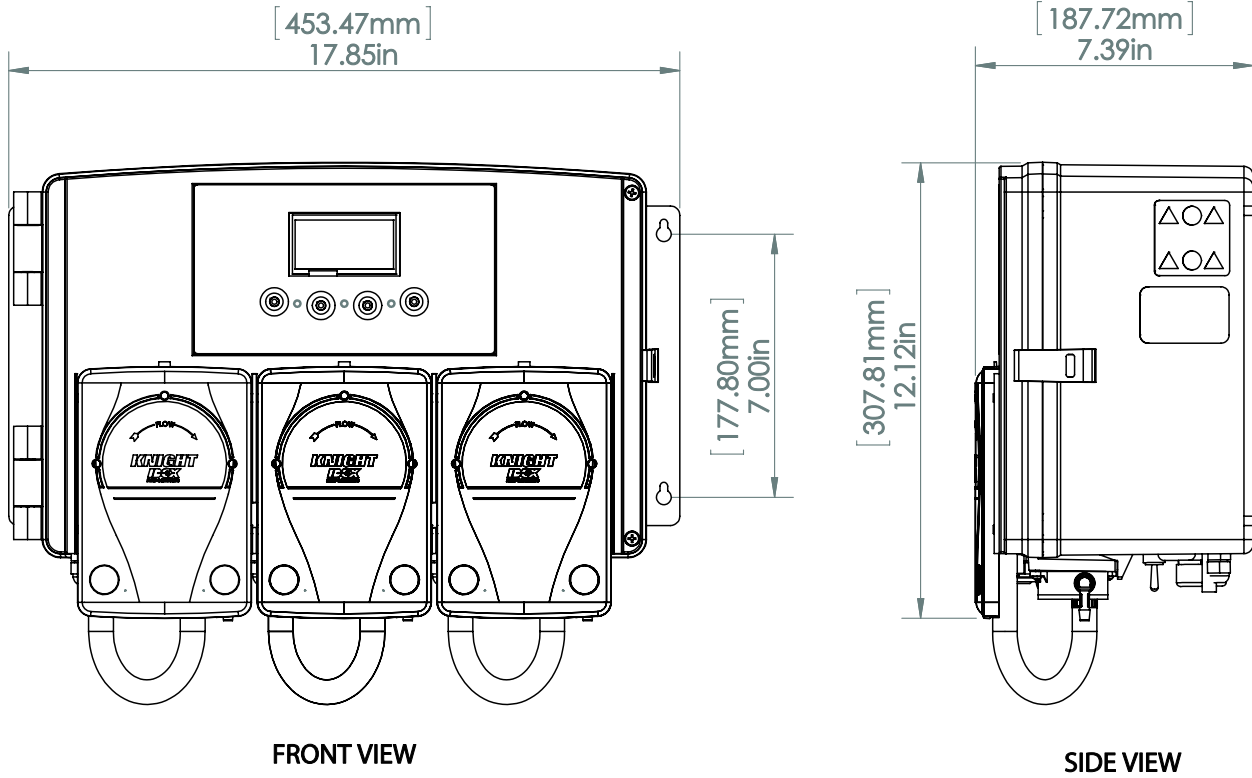

NOTE: The keyhole mounting holes
are 17" apart

WIRING DIAGRAM (115VAC)

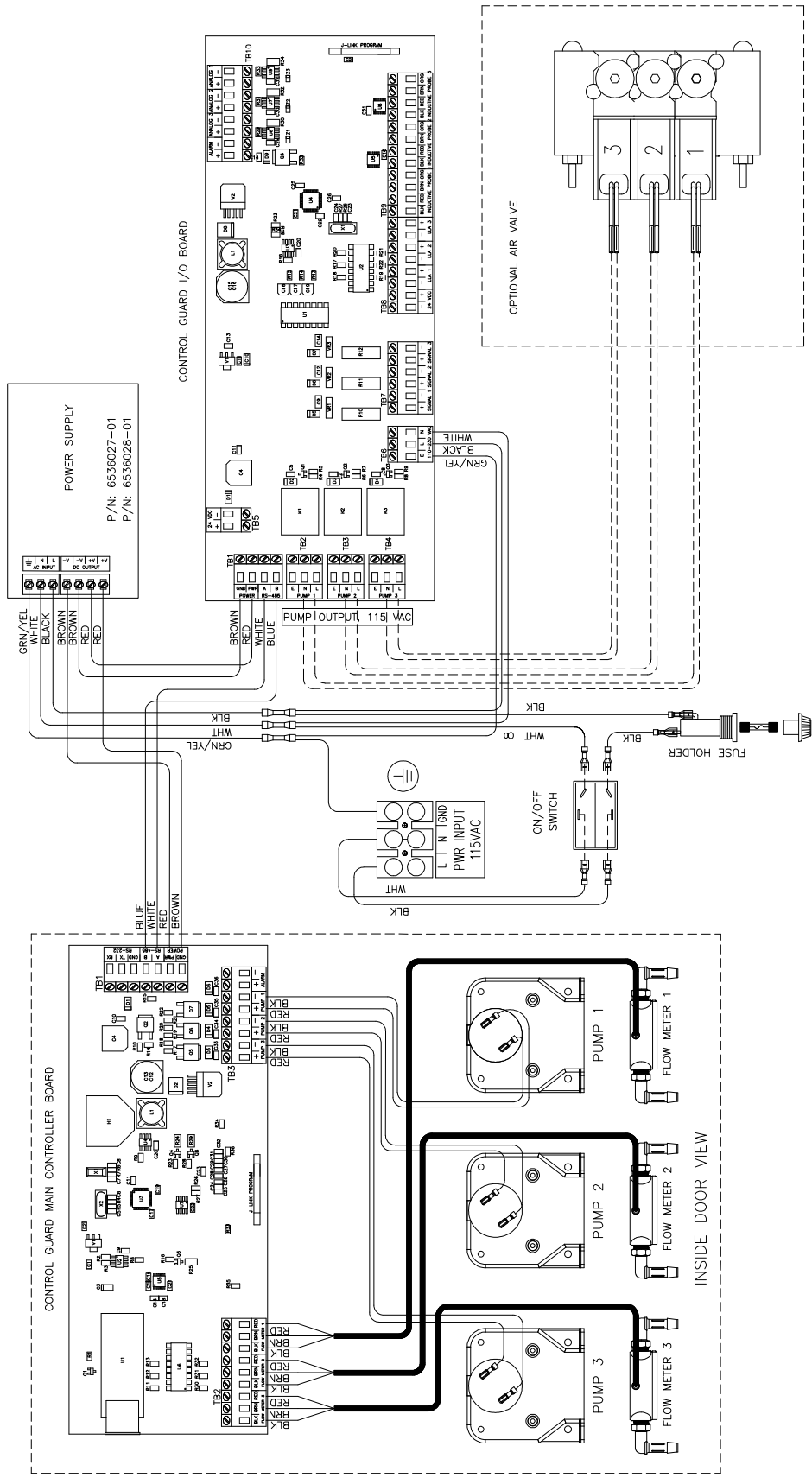

WIRING DIAGRAM (230VAC)

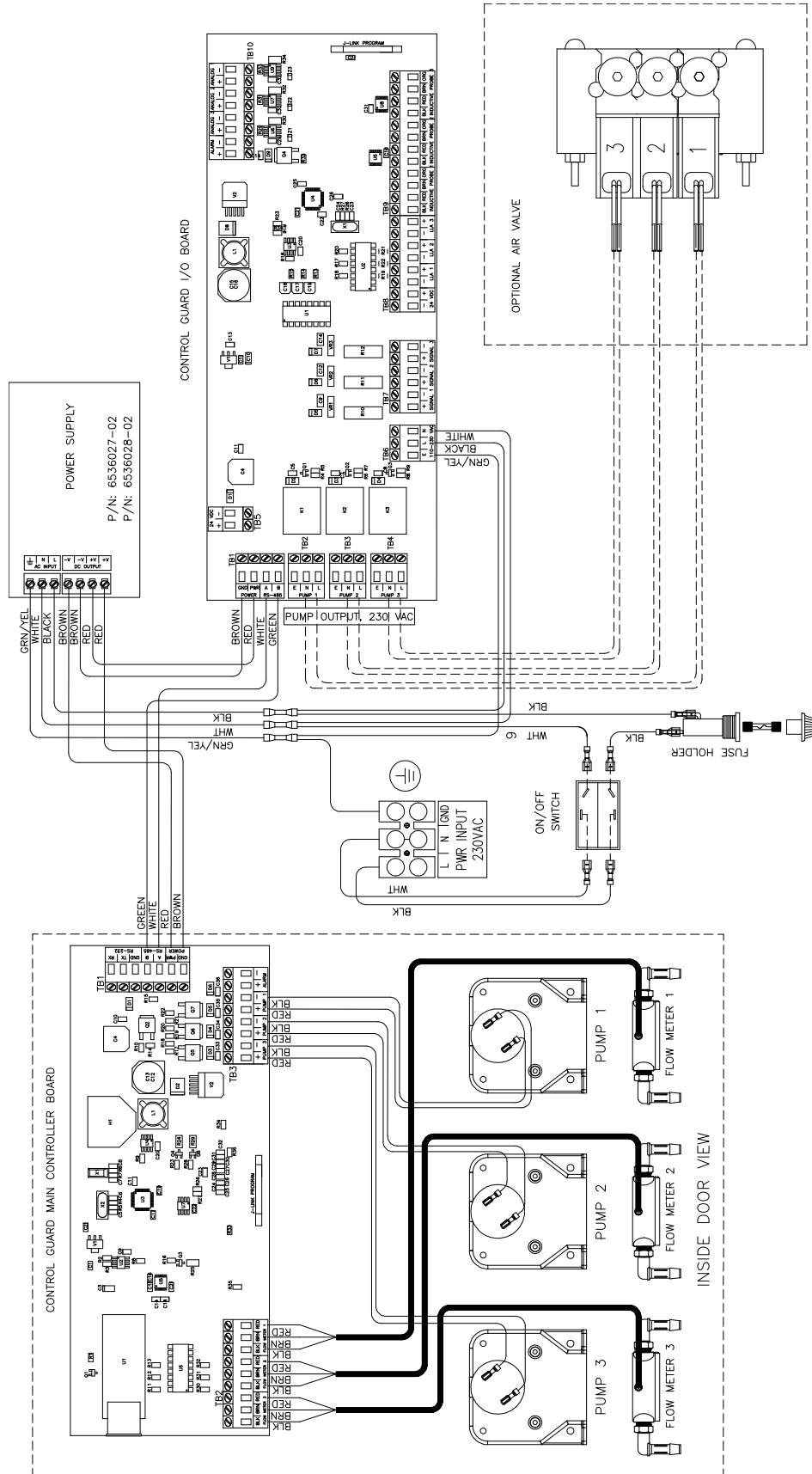

WIRING DIAGRAM FOR CONNECTING SIGNAL INPUTS



WIRING DIAGRAM FOR CONNECTING REMOTE INPUT SIGNALS

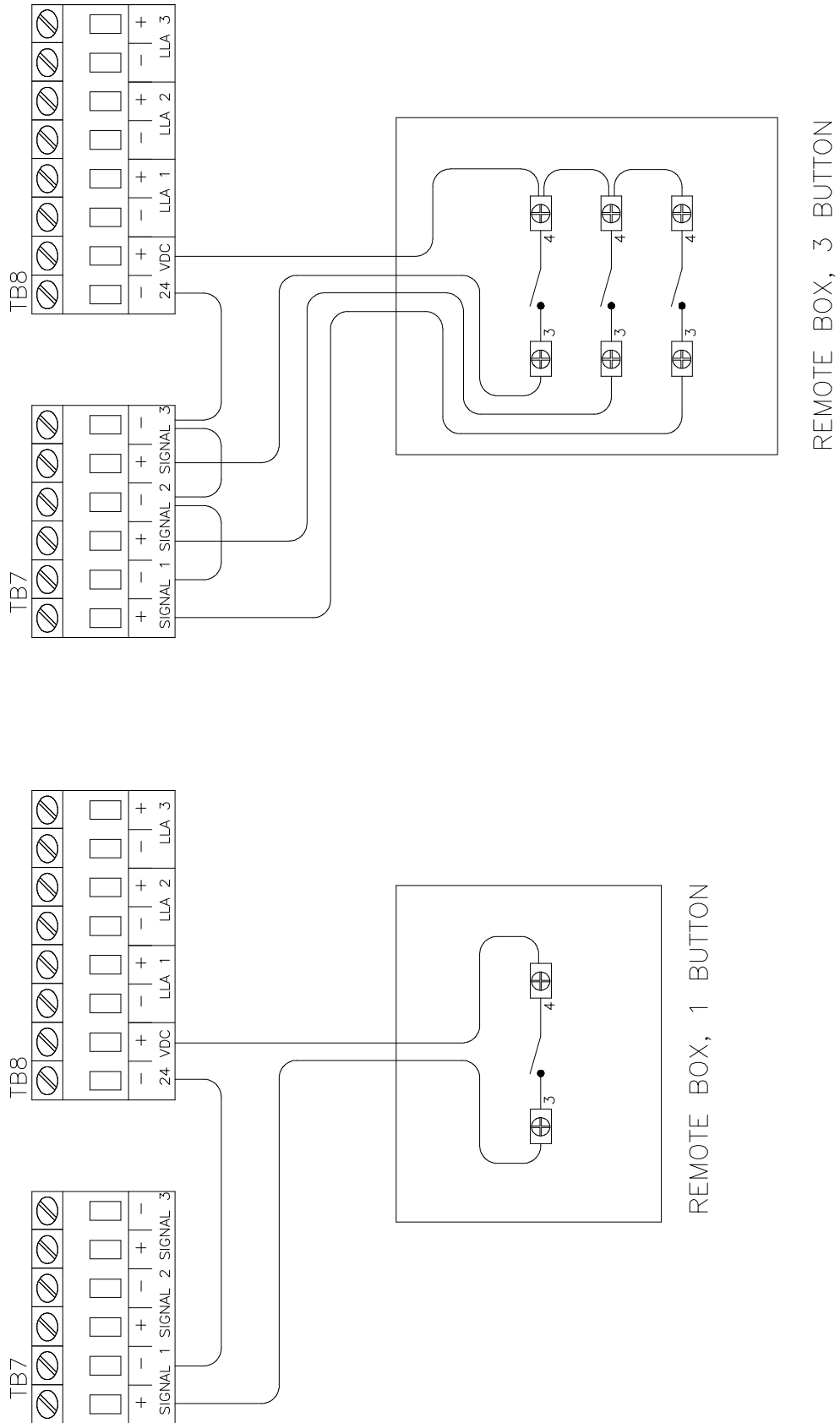

WIRING DIAGRAM FOR CONNECTING A LOW LEVEL SWITCH

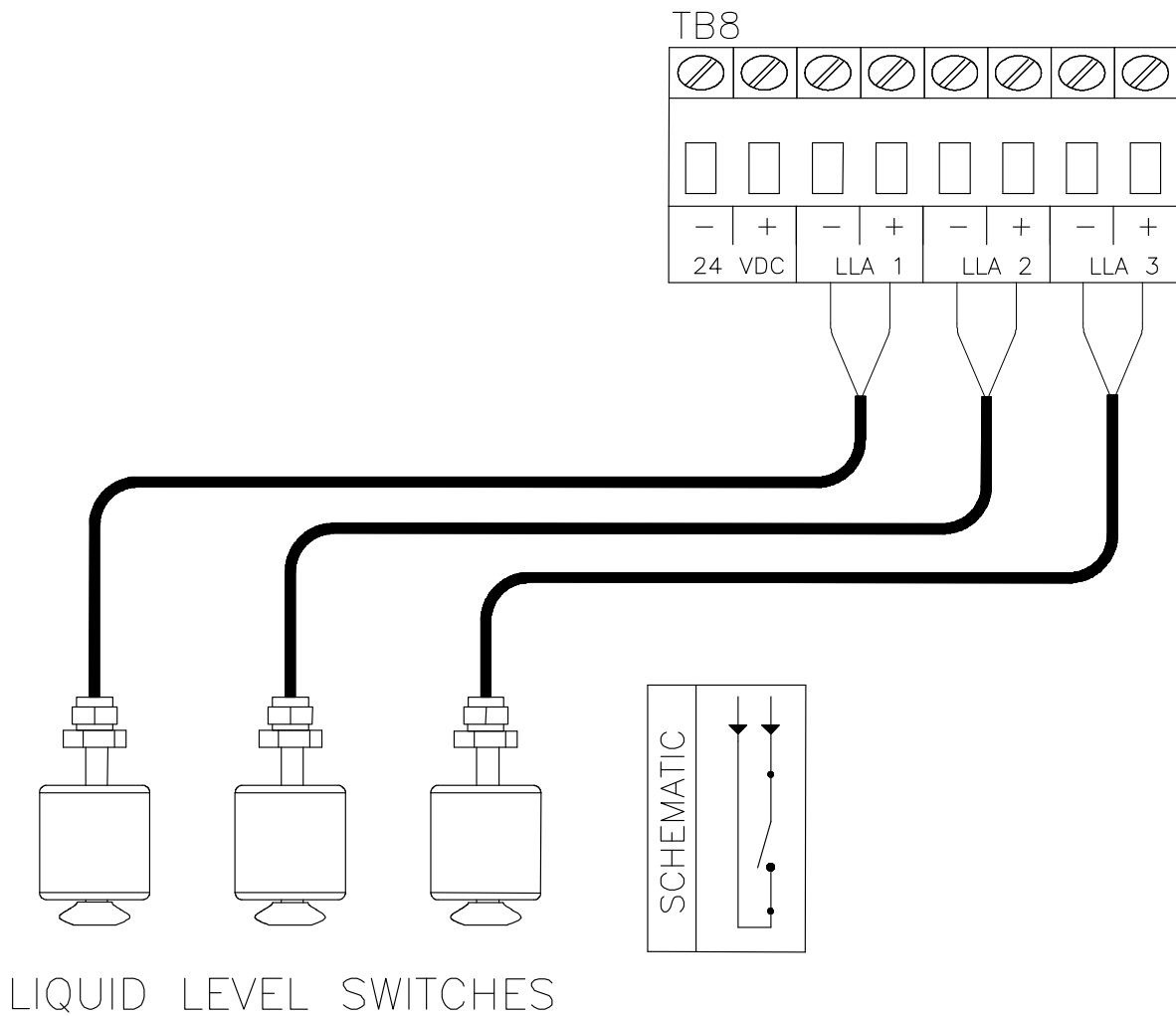

Note: the low level inputs are for dry contacts (no voltage)

WIRING DIAGRAM FOR CONNECTING KNIGHT INDUCTIVE PROBES (PN 6536033)

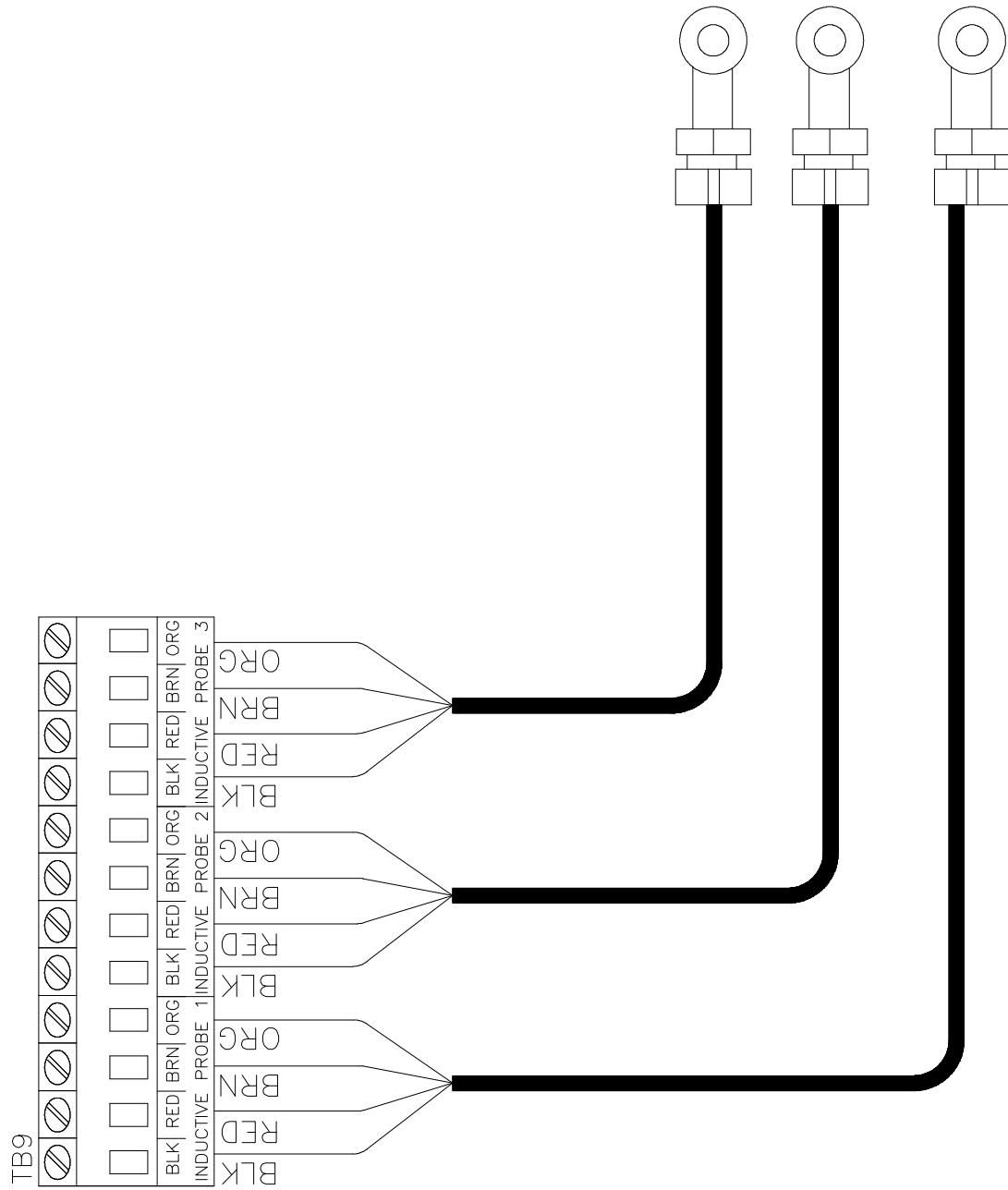

WIRING DIAGRAM FOR CONNECTING A 4-20MA DEVICE

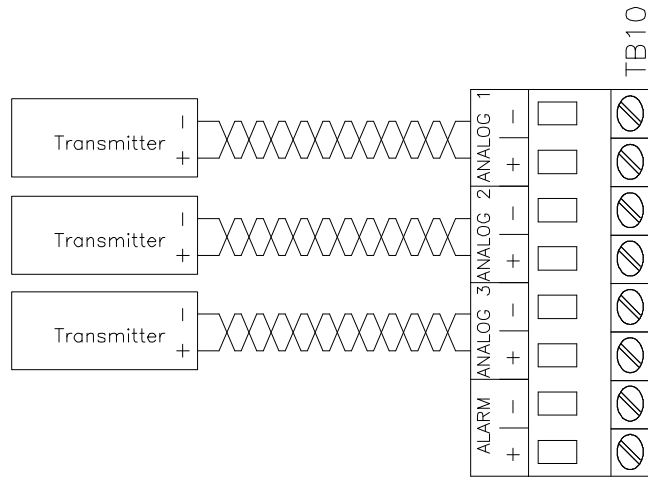

ACTIVE TRANSMITTER

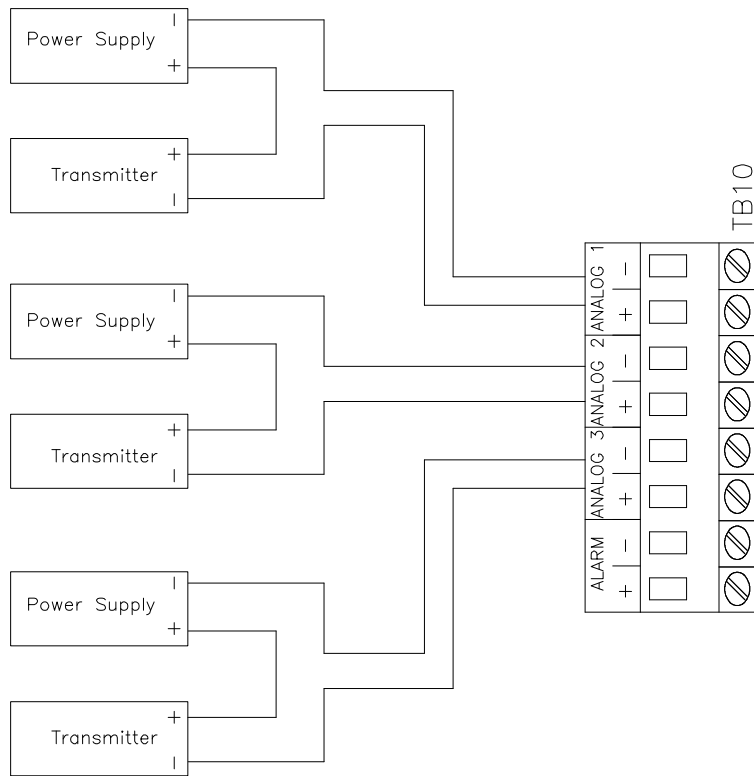

PASSIVE TRANSMITTER

WIRING DIAGRAM FOR CONNECTING ELECTRIC PUMP/VALVE (KNIGHT EDP PUMP DETAILED)

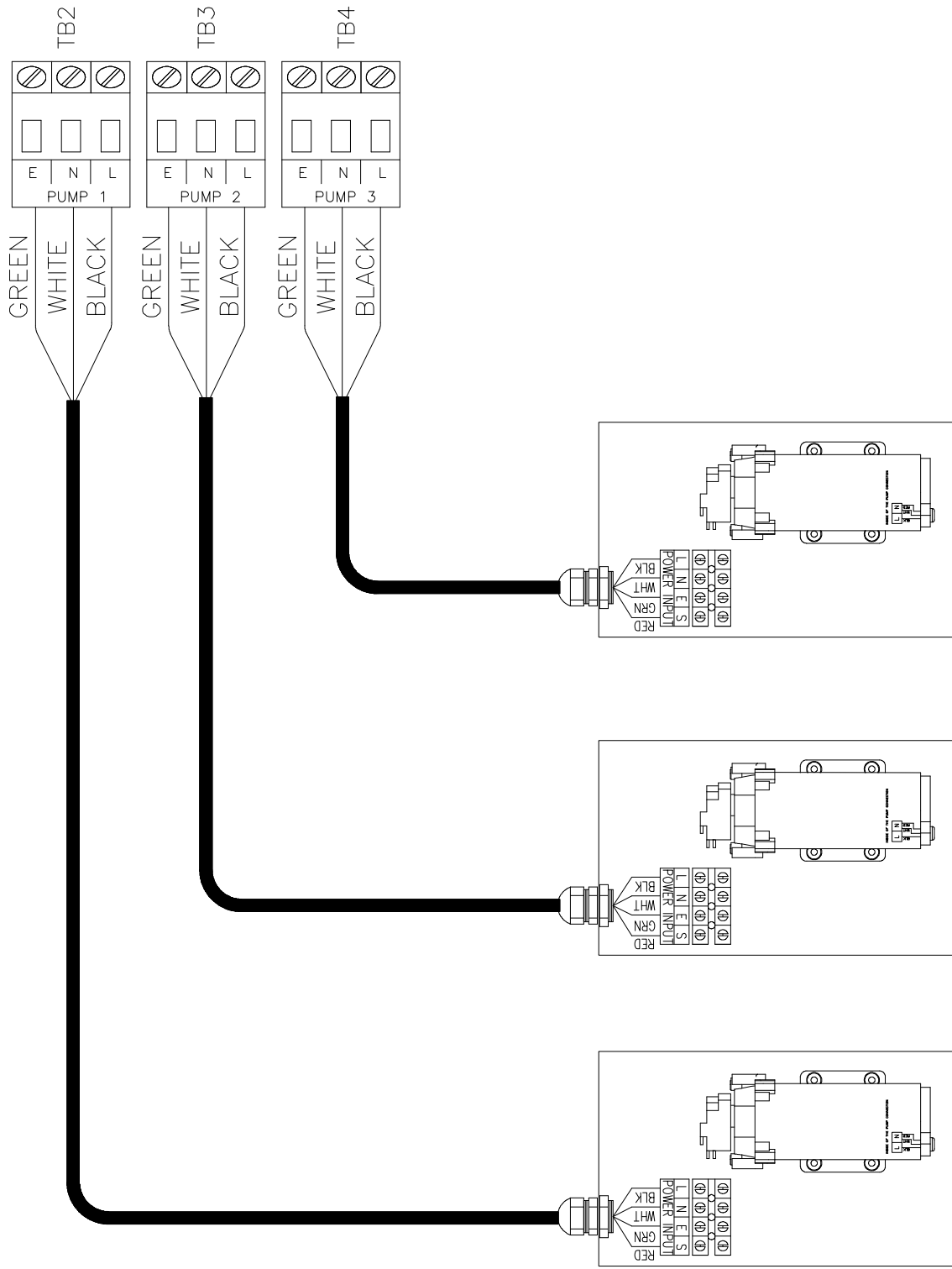

EXPLODED VIEWS

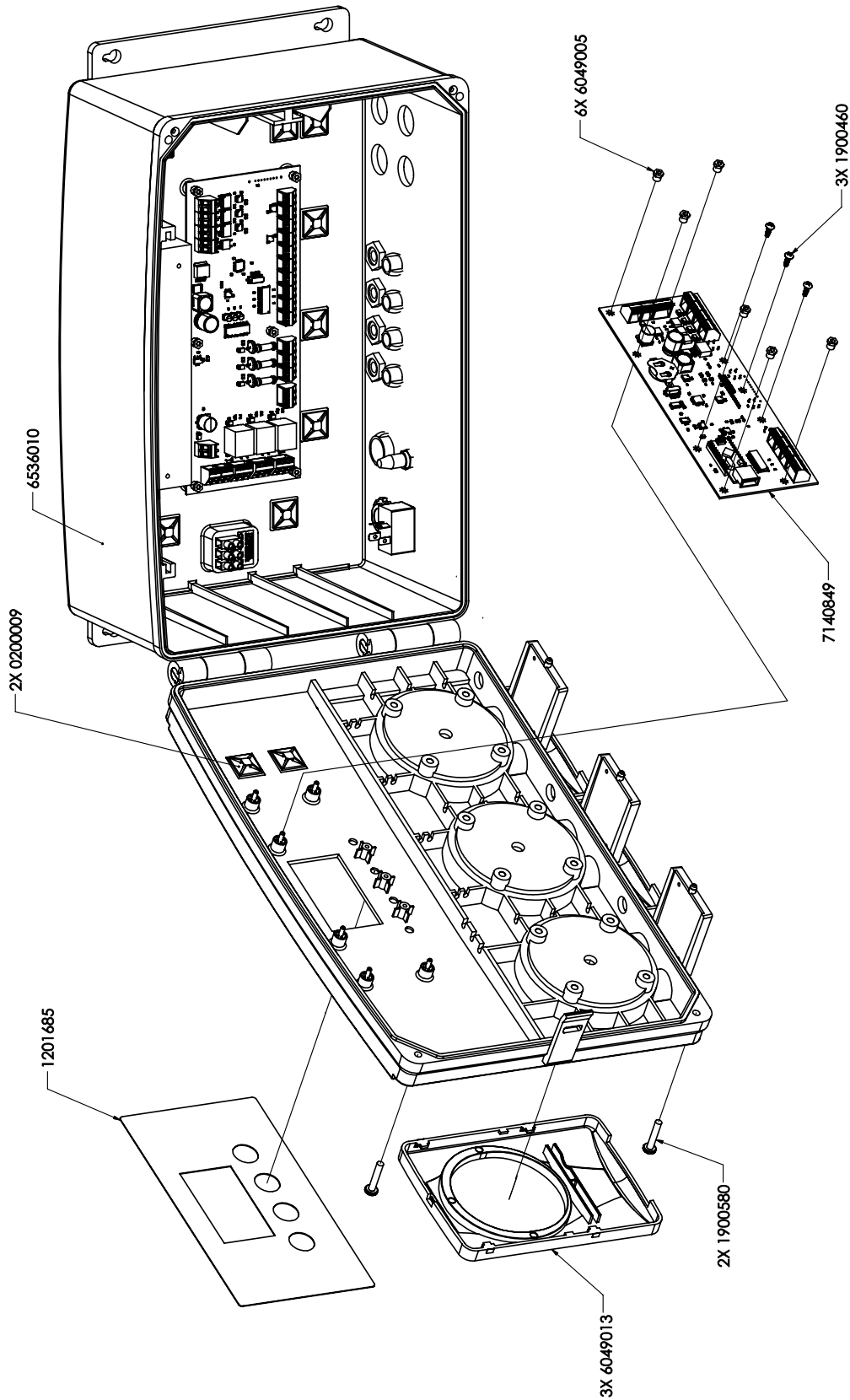

BASE MODEL
DOOR ASSEMBLY

EXPLODED VIEWS

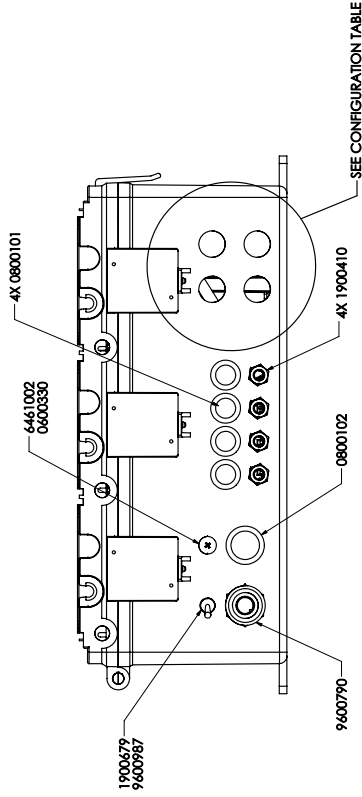
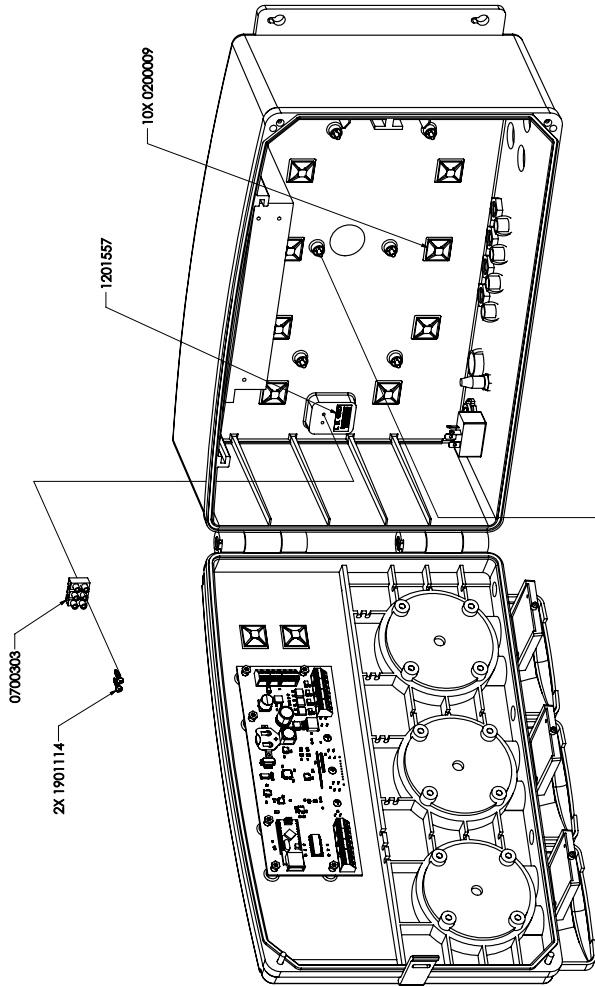

BASE MODEL
BODY ASSEMBLY

BASE MODEL
BOTTOM VIEW

EXPLODED VIEWS

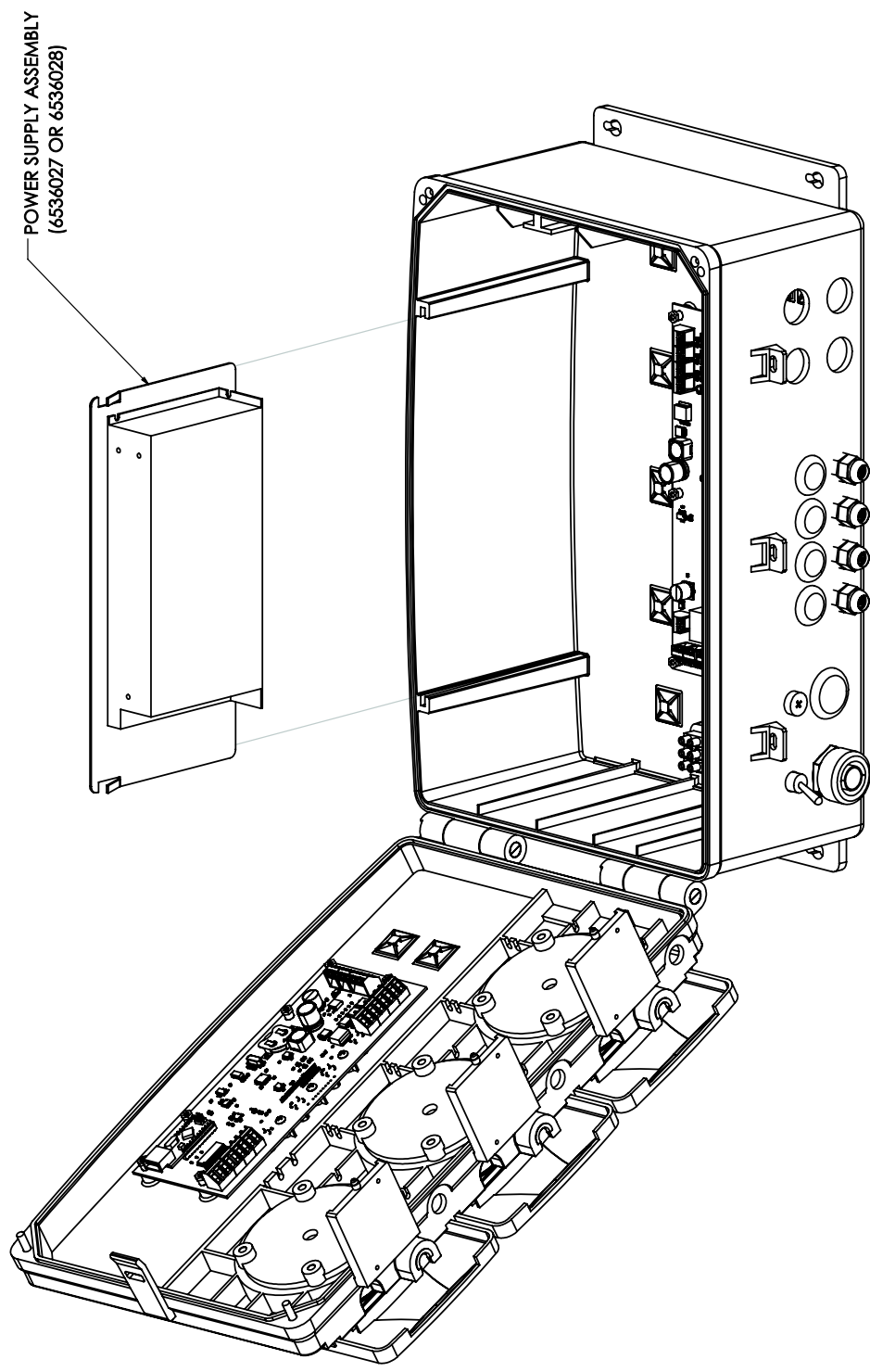

POWER SUPPLY
BOTTOM VIEW

EXPLODED VIEWS

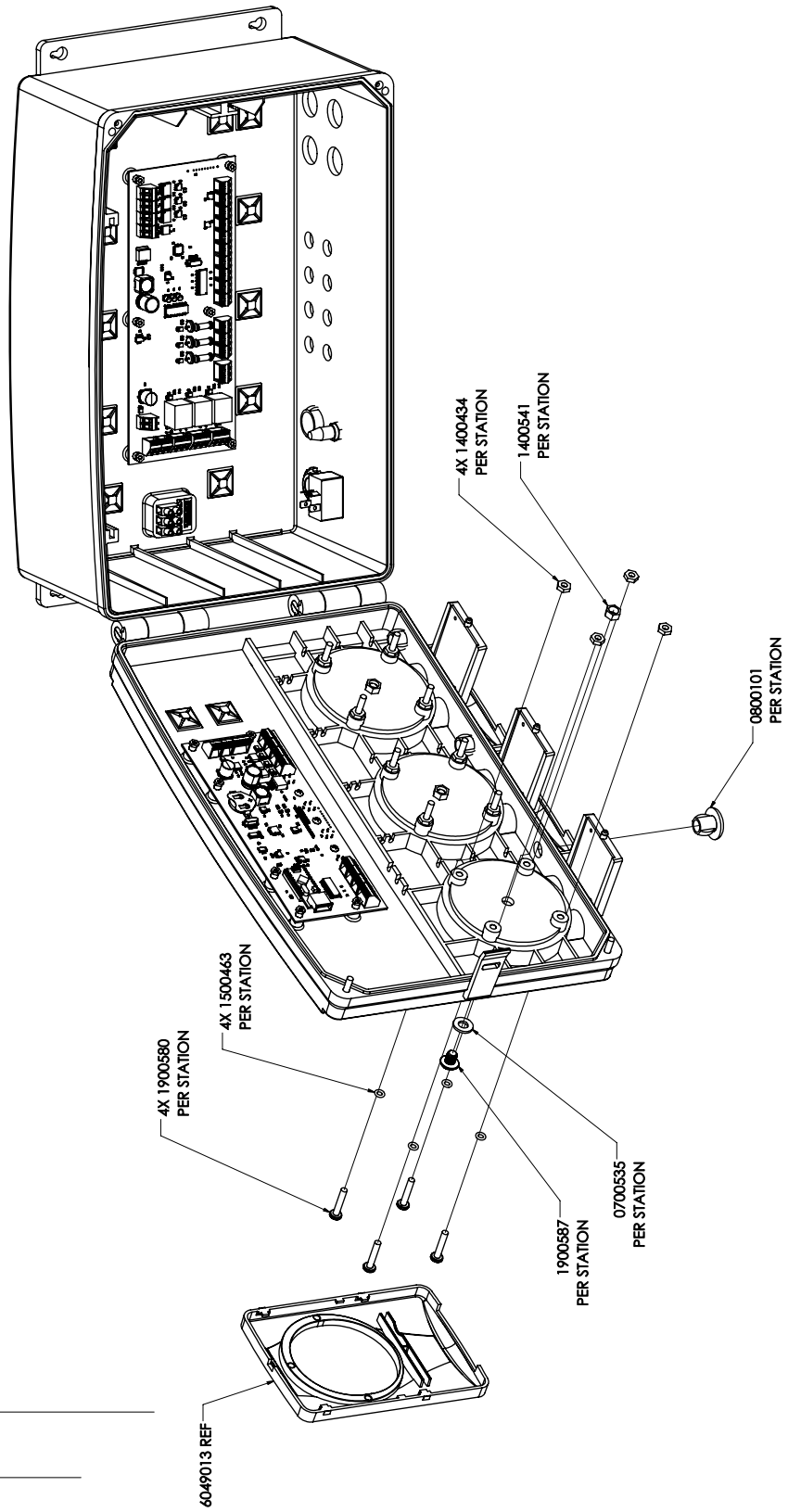

EMPTY PUMP STATION
PUMP "ZERO" KIT

EXPLODED VIEWS

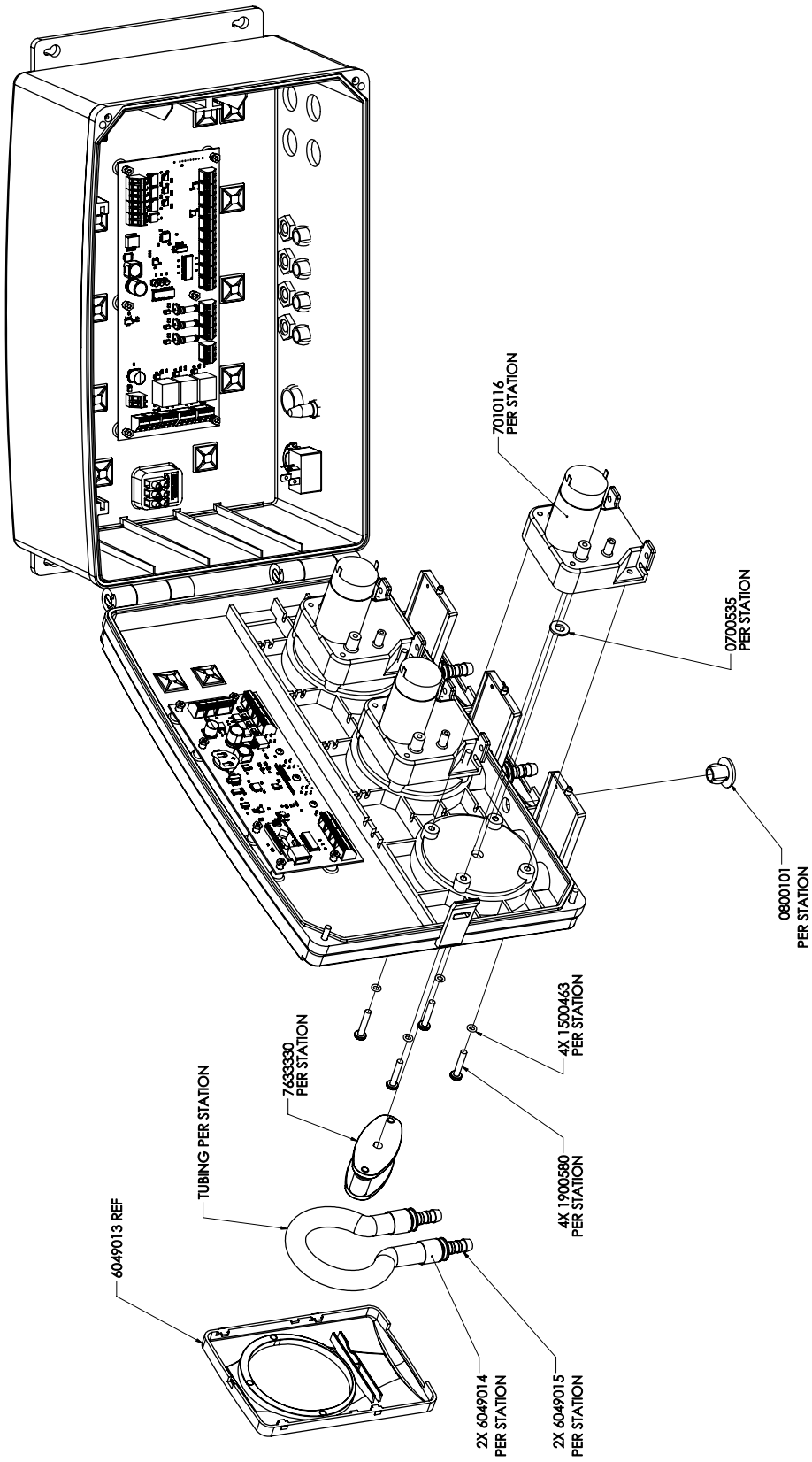

PUMP ONLY OPTION

EXPLODED VIEWS

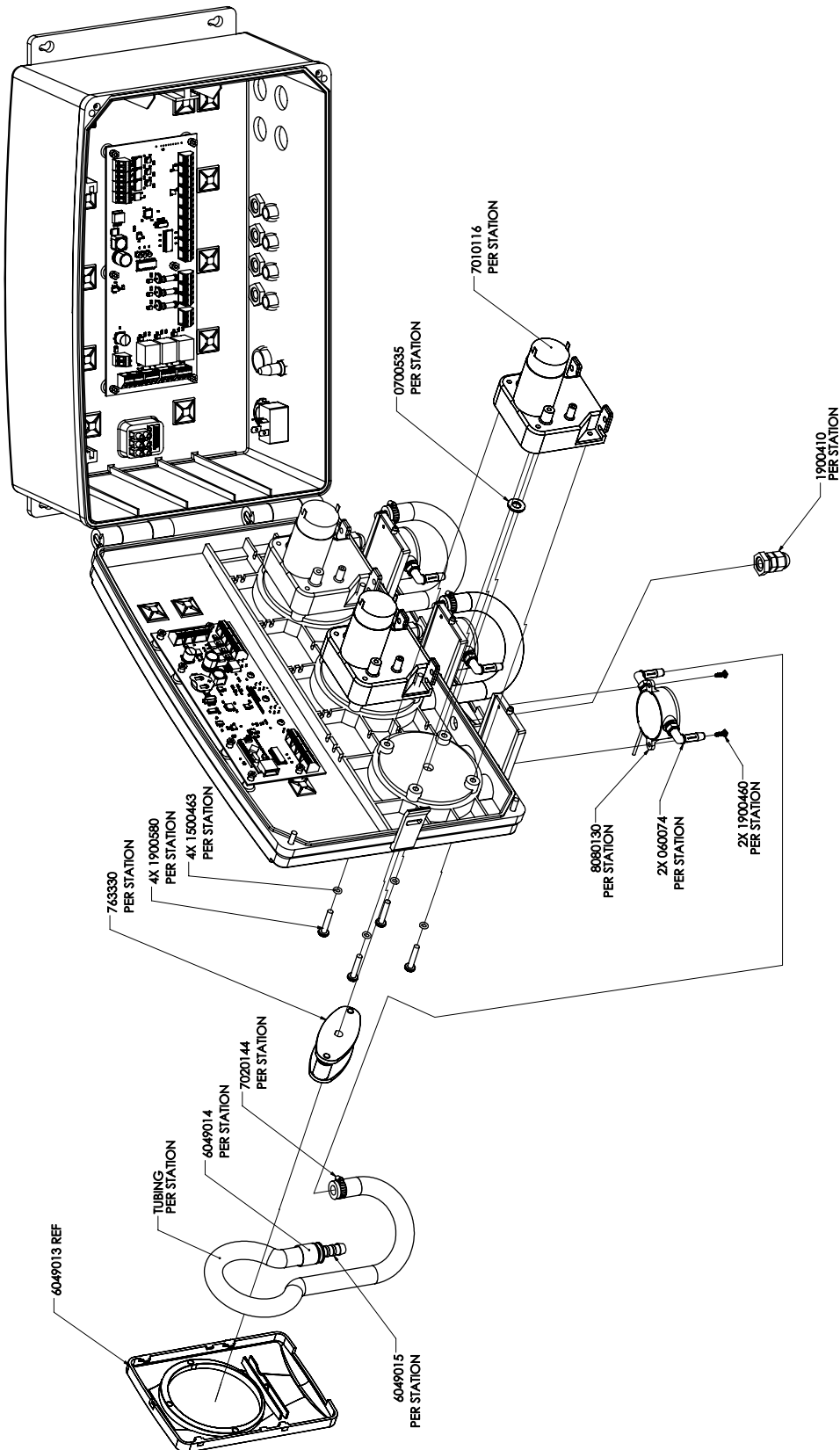

PUMP W/ FLOW METER OPTION

EXPLODED VIEWS

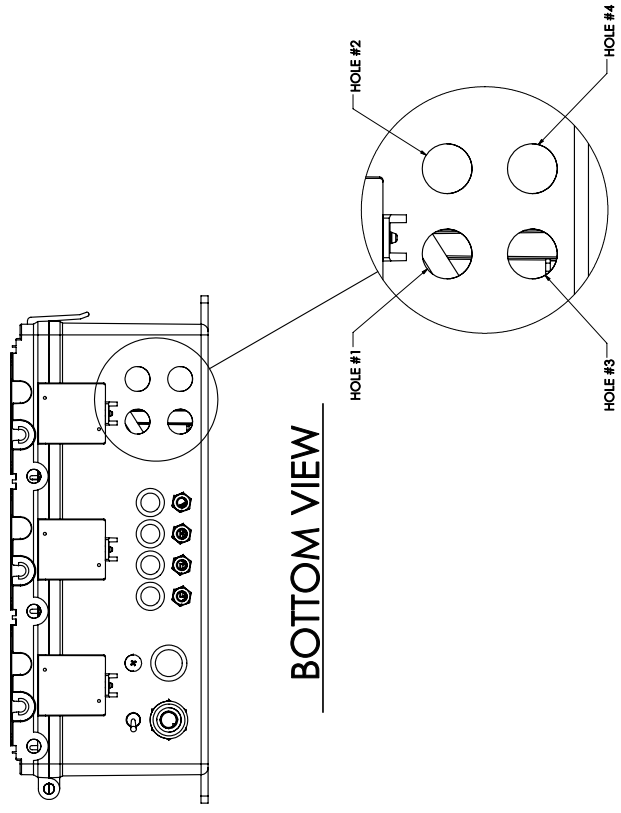

BOTTOM VIEW

ASSEMBLY CONFIGURATION TABLE

	HOLE #1	HOLE #2	HOLE #3	HOLE #4
6536013 (VALVE ZERO (KIT)	0800102	0800102	0800102	0800102
6536201 (VALVE ASSY)	0800102	0800102	1900400, 1900401, 1900402	1900400, 1900401, 1900402
6536202 (VALVE ASSY)	0800102	1900400, 1900401, 1900402	1900400, 1900401, 1900402	1900400, 1900401, 1900402
6536203 (VALVE ASSY)	1900400, 1900401, 1900402	1900400, 1900401, 1900402	1900400, 1900401, 1900402	1900400, 1900401, 1900402

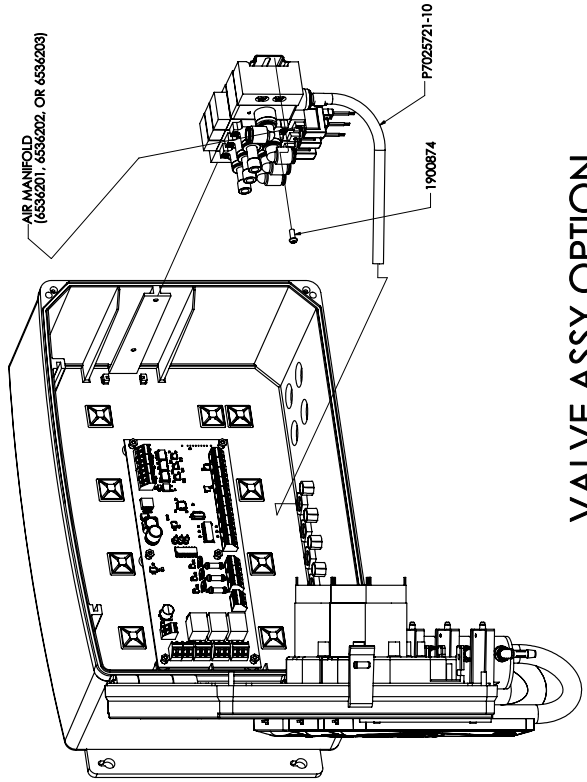

VALVE ASSY OPTION

TROUBLESHOOTING

Symptom	Indication	Things to Check
No Power	Blank (black) display	Verify main supply voltage Verify power cord plugged into outlet Verify main power to main terminal block both before and after the fuse Verify 5A fuse not blown
Calibration error	Red display with error message	Calibrate pump per steps in programming section
Flow-meter error	Red display with error message	Chemical container empty Air in chemical lines Debris in flow meter Loose flow meter wires
Probe error	Red display with error message	Loose probe wires Defective probe
Low level error	Red display with error message	Chemical container empty Loose wires on float switch Float on switch is stuck / jammed
Temperature error	Red display with error message	Solution tank is too hot or too cold Defective probe
I/O communication error	Red display with error message	Loose wires between main control and I/O boards Defective main control board Defective I/O board



KNIGHT, LLC
A Unit of IDEX Corporation
20531 Crescent Bay Drive
Lake Forest, CA 92630-8825
Phone: (949)595-4800
Fax: (949)595-4801
www.knightequip.com

EC – Declaration of Conformity

We declare that the product listed below, to which this Declaration of Conformity relates, is in conformity with the Standards and other Normative Documents listed below:

Equipment Description: **Advanced Chemical Concentration System**
Type/Model Number: **CONTROL GUARD ACCS™**

Low Voltage Directive - 2006/95/EC (and former Directive 73/23/EEC)
Standards to which Conformity is Declared:

Electrical Safety IEC/EN 61010-1:2010 (Third Edition) - Safety Requirements for Electrical Equipment for Measurement, Control, and Laboratory Use, Part 1: General Requirements.

For Information: The "Electrical Safety Test" took place at the CSA International, Irvine, CA, U.S.A

Electromagnetic Compatibility

EMC Directive - 2004/108/EC and former Directive 89/336/EEC as amended by 92/31/EEC and 93/68/EEC
Standards to which Conformity is Declared:

EMC Emissions: CISPR 11: Industrial, scientific and medical (ISM) radio-frequency
EN 55011: Equipment - Radio disturbance characteristics - Limits and methods of measurement

EN 61000-3-2: Limits for harmonic current emissions
EN 61000-3-3: Limitation of voltage changes, voltage fluctuations and flicker in public

EMC Immunity: EN 61326-1: 2006 Electrical Equipment Measurement, Control & Laboratory Use (Normal Environment)
EN 61000-4-2: Electrostatic discharge immunity test
EN 61000-4-3: Radiated, radio-frequency, electromagnetic field immunity test
EN 61000-4-4: Electrical fast transient/burst immunity test
EN 61000-4-5: Surge immunity test
EN 61000-4-6: Immunity to conducted disturbances, induced by diofrequency fields
EN 61000-4-11: Voltage dips, short interruptions and voltage variations immunity test

For Information: The "Electromagnetic Test" took place at the Northwest EMC, Irvine, CA, U.S.A

Certification Marking: 

We declared that the equipment specified above conforms to the referenced EU Directives and Harmonized Standards."

Signature:  Date: 05/25/2016

Name: Joah Bridwell Title: Engineering Manager

DISCLAIMER

Knight LLC does not accept responsibility for the mishandling, misuse, or non-performance of the described items when used for purposes other than those specified in the instructions. For hazardous materials information consult label, MSDS, or Knight LLC. Knight products are not for use in potentially explosive environments. Any use of our equipment in such an environment is at the risk of the user, Knight does not accept any liability in such circumstances.

WARRANTY

All Knight controls and pump systems are warranted against defects in material and workmanship for a period of ONE year. All electronic control boards have a TWO year warranty. Warranty applies only to the replacement or repair of such parts when returned to factory with a Knight Return Authorization (KRA) number, freight prepaid, and found to be defective upon factory authorized inspection. Bearings and pump seals or rubber and synthetic rubber parts such as "O" rings, diaphragms, squeeze tubing, and gaskets are considered expendable and are not covered under warranty. Warranty does not cover liability resulting from performance of this equipment nor the labor to replace this equipment. Product abuse or misuse voids warranty.

FOOTNOTE

The information and specifications included in this publication were in effect at the time of approval for printing. Knight LLC reserves the right, however, to discontinue or change specifications or design at any time without notice and without incurring any obligation whatsoever.

KNIGHT LLC (www.knightequip.com)

Knight Headquarters Tel: 949.595.4800 Fax: 949.595.4801	USA Toll Free Tel: 800.854.3764	Knight Canada Tel: 905.542.2333 Fax: 905.542.1536	Knight Europe Tel: 0044.1273.402780 Fax: 0044.1273.402781	Knight Australia Tel: 61.02.9352.1801 Fax: 61.02.9352.1899	Knight N. Asia Tel: 82.2.3481.6683 Fax: 82.2.3482.5742	Knight S. Asia Tel: 65.6763.6633 Fax: 65.6489.6723
--	---	--	--	---	---	---
