

# Ultra Wash DISHMACHINES

**Now with  
Open Impeller**



**KLE-235D**

**Mechanical  
Timer!**



**KLE-175GTM**

## ULTRA WASH SERIES - HIGH CAPACITY DISHMACHINES

Your customers want reliable dishmachines that can keep up with their high traffic operation, and you want a profitable return on the machines you install. Like yourself, many chemical service providers and restaurant equipment distributors turn to Knight for quality dishmachines with attractive profit margins.

Knight's Ultra Wash KLE-235D and KLE-175GTM are designed for your medium to high volume warewashing accounts. These robust, quality dishmachines come with easy-to-use and easy-to-service equipment features that directly lead to long term savings and profits.

The Ultra Wash Series Dishmachine offers reliable mechanical timer controls and comes with built-in chemical dispensers that deliver accurate amounts of detergent, sanitizer and rinse aid. Durable 1 HP high efficiency motor and advanced recirculating pump with open impeller provide impressive cleaning action. These features ensure your customers get proper chemical dosage and sparkling clean results with every wash load.

## KLE-235 D DOUBLE RACK DISHMACHINE

- Straight-Through, Double-Rack, Fill and Dump Operation
- Mechanical Timer Control w/90 Sec. Wash Cycle
- 74 Racks Per Hour
- Built-In Chemical Metering Pumps – Det., Sani., Rinse
- Two 1-Horse Power Motor with Open Impeller Provide Better Cleaning Action and Reduce Pump Service
- Automatic Start/Stop
- 14 Gauge #304 Stainless Steel Pan Construction
- Internal Scrap Trap
- Top Mounted Temperature Gauge

## KLE-175 GTM UPRIGHT DISHMACHINE

- Straight-Through or Corner Configuration
- Mechanical Timer Control w/90 Sec. Wash Cycle
- Fill and Dump Operation
- 37 Racks Per Hour
- Built-In Chemical Metering Pumps – Det., Sani., Rinse
- 1-Horse Power Pump Motor with Open Impeller
- Automatic Start/Stop
- 14 Gauge #304 Stainless Steel Pan Construction
- External Scrap Trap Accessible From Front or Side
- Top Mounted Temperature Gauge

# Ultra Wash DISHMACHINES

## **KLE-235 D – P/N 9000023-01**

Operating Capacity:	74 Racks Per Hour
Operating Cycle:	90 Seconds
Wash Time:	47 Seconds
Rinse Time:	28 Seconds
Drain:	15
Wash Tank Capacity:	3.8 Gallons
Wash Pump Capacity:	98 Gal./Min.
Recommended Wash Temperature:	120° minimum
Water Inlet:	3/4"
Drain I.P.S.:	1-1/2"
Wash Pump Motor:	1HP
Dimensions:	25"x44"x67"
Table Height:	34"
Max. Clearance For Dishes:	16-3/4"
Standard Dish Rack:	(2) 20"x20"
Shipping Weight:	350 lbs.
Electrical Rating:	115V
Load Amps:	28

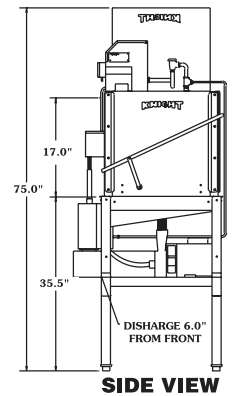
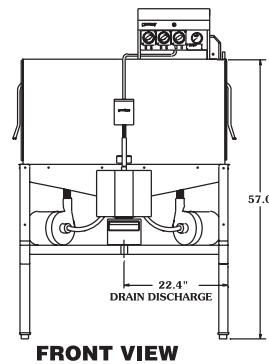
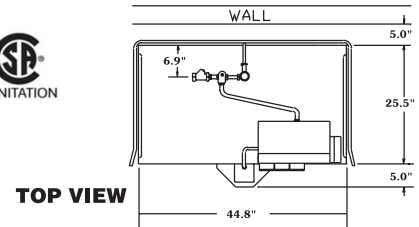

## **KLE-175 GTM – P/N 9000175-M1**

Operating Capacity:	37 Racks Per Hour
Operating Cycle:	90 Seconds
Wash Time:	45 Seconds
Rinse Time:	30 Seconds
Drain:	15
Wash Tank Capacity:	1.75 Gallons
Wash Pump Capacity:	58 Gal/Min.
Recommended Wash Temperature:	120° minimum
Water Inlet:	3/4"
Drain I.P.S.:	1-1/2"
Wash Pump Motor:	1 HP
Dimensions:	25.5"x25.5"x67"
Table Height:	34"
Max. Clearance For Dishes:	17"
Standard Dish Rack:	20"x20"
Shipping Weight:	200 lbs.
Electrical Rating:	115V
Load Amps:	14

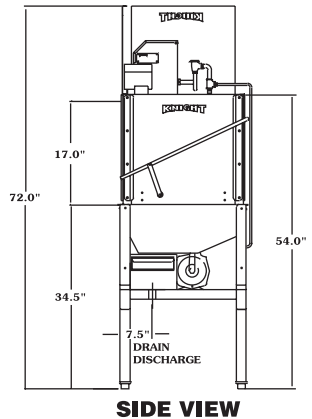
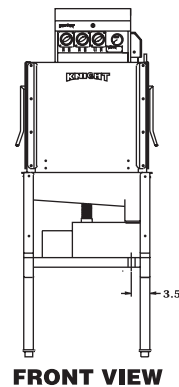
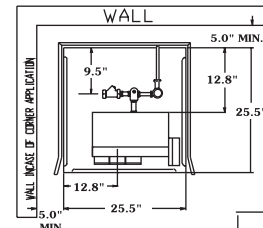

### **KNIGHT LIMITED WARRANTY**

All Knight Dishmachines are warranted against defects in material and workmanship for a period of THREE years. Warranty applies only to the replacement or repair of such parts when returned to the factory with a KRA number, freight prepaid and found to be defective upon factory authorized inspection. Warranty replacement for components parts purchased by Knight such as relays, motors and timers are limited to warranty by manufacturer. Rubber and synthetic rubber parts such as "O" rings, diaphragms, squeeze tubing and gaskets or bearings, seals or parts and components not easily identified by date code are considered expendable and are not covered under warranty. Warranty does not cover liability resulting from performance of this equipment nor the labor to replace this equipment. Product abuse or misuse voids warranty. Knight electronic boards are warranted against defects in material and workmanship for a period of TWO years. Knight products are not for use in potentially explosive environments. Any use of our equipment in such an environment is at the risk of the user. Knight does not accept any liability in such circumstances.

### **DISTRIBUTOR**

<b>Knight Headquarters</b> Toll Free (800)854-3764 Tel (949)595-4800 Fax (949)595-4801 www.knightequip.com	<b>Georgia Branch</b> Toll Free (800)241-7789 Tel (770)760-8777 Fax (770)761-0199	<b>Canada Branch</b> Tel (905)542-2333 Fax (905)542-1536	<b>UK Branch</b> Tel 44.1293.615.570 Fax 44.1293. 615.585	<b>Australia Branch</b> Tel 61.2. 9725. 2588 Fax 61.2. 9725.2025	<b>N. Europe Branch</b> Tel 31.53.428.5800 Fax 31.53.428.5809	<b>France/Italy</b> Tel 39.338.782.3696	<b>N. Asia Branch</b> Tel 82.19.218.5743 Fax 82.2.3482.5742 <b>S. Asia Branch</b> Tel (+)65.9170.0984 Fax (+)65.6489.9723
--	--	--	---	--	---	--	--