

# GT Series

## KLE-175 GT / KLE-150 GT

### GT SERIES DISHMACHINES – BEST IN VALUE

Performance is everything in a busy kitchen and your customers depend on reliable dishmachines that won't breakdown. Knight sets the standard for warewash technology with our high quality, attractively priced, low energy GT dishmachine line – which is unquestionably the best value in the industry. The KLE-175 GT upright and KLE-150 GT undercounter dishmachines are quality engineered and manufactured with field proven parts and materials. As a result, your customers get uncompromised reliability and exceptional uptime performance, year after year.

The GT Series offer reliable performance and attractive pricing structures that will satisfy your customers and give you higher returns on your investment. The GT dishmachines deliver consistent, high pressure cleaning power with a 1 HP high efficiency motor and advanced recirculating pump with open impeller. Other value-added features include: microprocessor control with four cycle time selections, chemical feed pumps with exclusive long-life squeeze tubes, high performance upper and lower spray arms, #304 stainless steel construction, and more. That's why world-leading chemical suppliers and restaurant equipment distributors chose Knight's GT dishmachines.



**KLE-175 GT**



**KLE-150 GT**

### KLE-175 GT UPRIGHT

The KLE-175 GT upright can clean up to 46 racks per hour and is perfect for restaurants and fast food operations. KLE-175 GT can be configured for straight-through or corner operation. This all-inclusive dishmachine even comes with a convenient water connection point and an electrical supply hook-up terminal for other kitchen chemical dispensers, saving you precious time and space.

### KLE-150 GT UNDERCOUNTER

The KLE-150 GT undercounter delivers the cleaning power and performance of the KLE-175 GT in a smaller footprint. KLE-150 GT is perfect for space limited operations such as fast food restaurants, delis and bars. This compact dishmachine offers a 14" clearance that accommodates serving trays, platters and other kitchenware. For additional height, 12" leg extensions can be added.

# The GT Series Advantage!

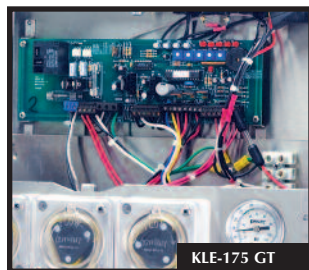

**GT MICROPROCESSOR**

The 'GT' microprocessor control is the first non-mechanical control made for Low Energy Dishmachines. Field proven, this efficient, state of the art control can provide four wash cycle time selections – 72, 90, 120, and 360 Sec.



**KLE-175 GT TOP MOUNTED CONTROL BOX**

Top mounted control panel and temperature gauge is easy to service. Exterior mounted feed pump comes with industry leading long-life squeeze tubes.



**KLE-150 GT REMOVABLE CONTROL BOX**

KLE-150 GT control box slides in and out to expose motor, water valve and drain solenoid to reduce service time.



**SCRAP TRAP**

The KLE-150 GT is the only under-counter dishmachine on the market equipped with an external scrap trap to remove food soil from the machine after every wash cycle.

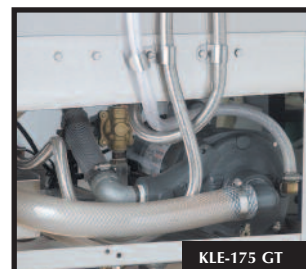

**HIGH EFFICIENCY MOTOR**

The 'GT' 1 Horse Power motor and recirculating pump produces real cleaning power that meets the latest CSA standards for cleaning and sanitation.

The KLE-175 GT scrap trap can be configured for front or side access.

## GT SERIES OPTIONS - FACTORY INSTALLED OR RETROFIT KITS!



**Sustaining Heater** maintains hot water (140°F) in between racks for the best cleaning results.



**Pump-Out Drain** is available for restricted or upward drainage requirements.

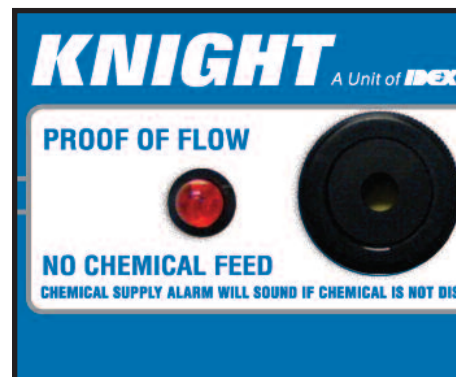

**Proof of Delivery** is designed to alert operators of an interruption in the flow of liquid chemical via a visual and audio alarm.





## KLE-175 GT Upright

- Straight-Through or Corner Configuration
- Microprocessor Based Electronic Control With 72, 90, 120 or 360 Second Wash Cycles
- Built-in Chemical Metering Pumps – Detergent, Sanitizer, Rinse
- Automatic Start/Stop
- Convenient Drain/Fill Switch
- Active Wash Cycle LED Light
- Water Connection Point for Water Driven Dispensing Systems such as Sink Mate and Sink Bowl
- 14 Gauge #304 Stainless Steel Construction
- Front or Side Accessible Scrap Trap
- Open Impeller with Pause Cycle
- Internal Pump Screen
- Electronic Dispenser Power Terminal



**COMPACT BOOSTER WATER HEATER**  
Clean and sanitize with really hot water. This booster heater offers 180° rinse water for fast, safe and efficient cleaning.



WATER CONNECTION POINT



BUILT-IN POWER TERMINAL



MODEL	PART #	DESCRIPTION
KLE-175 GT	9000175-01	KLE-175GT dishmachine, straight or corner convertible, single rack. 120V 60Hz.
KLE-175 GT	9000175-03	KLE-175GT dishmachine, straight or corner convertible, single rack. 240V 50/60Hz.
KLE-175 GT	9641739	Compact booster water heater.
	7501318	Low level alarm/proof of delivery installation kit.



## KLE-150 GT Undercounter

- Microprocessor Based Electronic Control with 72, 90, 120 and 360 Second Wash Cycles
- Built-in Chemical Metering Pumps – Detergent, Sanitizer, Rinse
- Automatic Start/Stop
- Convenient Drain/Fill Switch
- Active Wash Cycle LED Light
- 14 Gauge #304 Stainless Steel Construction
- External Scrap Trap
- Slide Out Control Box
- Open Impeller
- Internal Pump Screen
- Electronic Dispenser Power Terminal



MODEL	PART #	DESCRIPTION
KLE-150 GT	9000150-01	KLE-150GT undercounter dishmachine, single rack. 120V 60Hz.
KLE-150 GT	9000150-03	KLE-150GT undercounter dishmachine, single rack. 240V 50/60Hz.
KLE-150 GT	9000150-H1	KLE-150GT dishmachine with factory installed tank heater. 120V 60Hz
KLE-150 GT	9000150-P1	KLE-150GT dishmachine with factory installed pump out drain. 120V 60Hz
KLE-150 GT	9000150PH1	KLE-150GT dishmachine with factory installed tank heater and pump out drain. 120V 60Hz
KLE-150 GT	9640211	12" Leg Extension. Kit includes four 12" legs to elevate KLE-150 GT
	7501318	Low level alarm/proof of delivery installation kit.

# GT Series

## DISHMACHINES

### KLE-175 GT



Operating Cycle:	<b>72 Sec.</b>	<b>90 Sec.</b>	<b>120 Sec.</b>
Operating Capacity: Racks Per Hour	46	37	30
Wash Time:	37 Sec.	45 Sec.	55 Sec.
Rinse Time:	24 Sec.	30 Sec.	50 Sec.
Drain Time:	11 Sec.	15 Sec.	15 Sec.
Wash Tank Capacity:	1.75 Gallons		
Wash Pump Capacity:	57 GPM		
Recommended Wash Temperature:	140 Degrees		
Water Inlet:	3/4"		
Drain I.P.S.:	1.5"		
Wash Pump Motor:	1 HP		
Dimensions:	25.5" D x 25.5" W x 67" H		
Table Height:	34"		
Max. Clearance For Dishes:	17"		
Standard Dish Rack:	20" x 20"		
Shipping Weight:	280 Pounds		
Electrical Rating:	120V 60Hz, 240V 50/60Hz		
Load Amps:	14, 7		

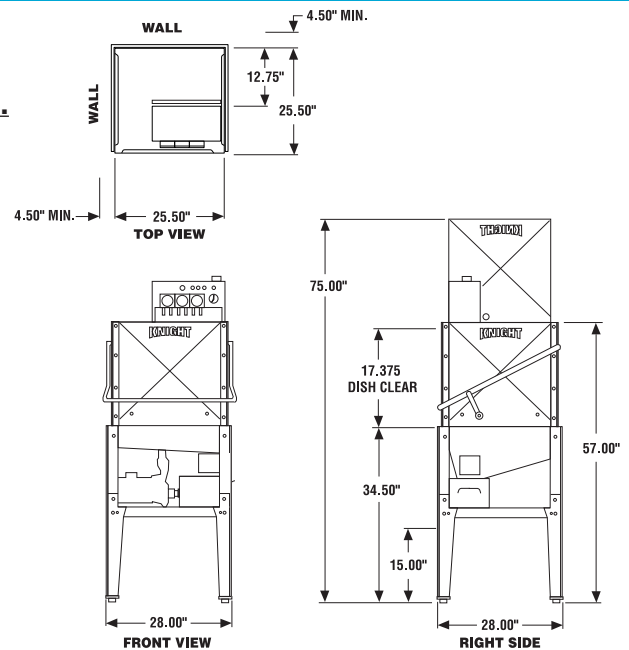

### KLE-150 GT



Operating Cycle:	<b>90 Sec.</b>	<b>120 Sec.</b>
Operating Capacity: Racks Per Hour	37	30
Wash Time:	45 Sec.	55 Sec.
Rinse Time:	30 Sec.	50 Sec.
Drain Time:	15 Sec.	15 Sec.
Wash Tank Capacity:	1.50 Gallons	
Wash Pump Capacity:	46 GPM	
Recommended Wash Temperature:	140 Degrees	
Water Inlet:	3/4"	
Drain I.P.S.:	1.5"	
Wash Pump Motor:	1 HP	
Dimensions:	25"D x 24"W x 34.75"H	
Table Height:	8"	
Max. Clearance For Dishes:	14.5"	
Standard Dish Rack:	20" x 20"	
Shipping Weight:	190 Pounds	
Electrical Rating:	120V 60 Hz, 240V 50/60Hz	
Load Amps:	14, 7	

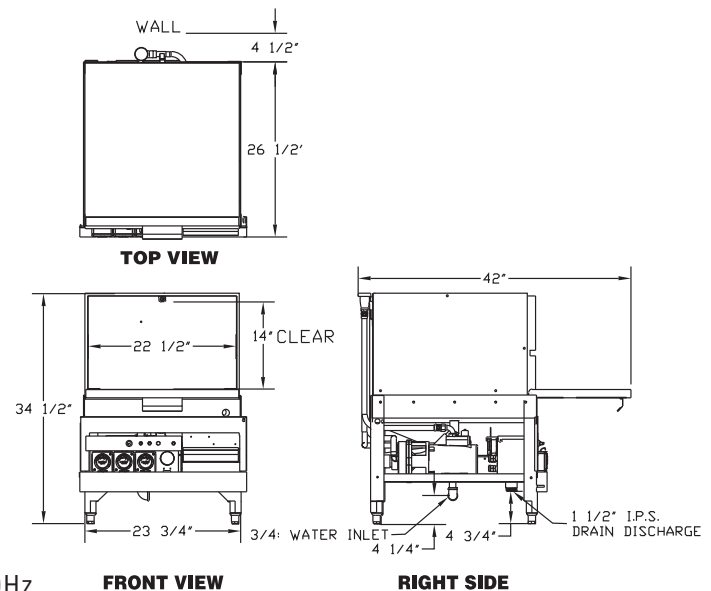

### KNIGHT LIMITED WARRANTY

Knights controls and pump systems are warranted against defects in material and workmanship for a period of ONE YEAR. All Electronic Control Boards have a TWO YEAR warranty. Warranty applies only to the replacement or repair of such parts when returned to the factory with a KRA number, freight prepaid and found to be defective upon factory inspection. Rubber and synthetic rubber parts such as "O" rings, diaphragms, squeeze tubing and gaskets are considered expendable and are not covered under warranty. Warranty does not cover liability resulting from performance of this equipment nor the labor to replace this equipment. Product abuse or misuse voids warranty. Knight products are not for use in potentially explosive environments. Any use of our equipment in such an environment is at the risk of the user. Knight does not accept any liability in such circumstances.

### KNIGHT DISCLAIMER

The information and specifications included in this publication were in effect at the time of approval for printing. Knight, LLC, reserves the right, however, to discontinue or change specifications or design at any time without notice and without incurring any obligation whatsoever.

**Knights Headquarters**  
Toll Free (800)854-3764  
Tel (949) 595-4800  
Fax (949)595-4801  
www.knightequip.com

**Knights Canada**  
Tel (905)542-2333  
Fax (905)542-1536

**Knights Europe**  
Tel +44(1323)514.855  
Fax +44(1323)514.828

**Knights Australia**  
Tel +61(02)4223.7450  
Fax +61(02)4271.8136

**Knights N. Asia**  
Tel +82(2)3481.6683  
Fax +82(2)3482.5742

**Knights S. Asia**  
Tel +65.9170.0984  
Fax +65.6489.6723