



KNIGHT®

*Trusted Solutions,
Making Cleaning Easy™*



Innovative Tools For a Cleaner World

**FACILITY
SOLUTIONS**





Surface Cleaning

While Knight offers a broad line of dispensers for many different applications, our focus has always been to deliver precise chemistries at the ideal time, featuring the most reliable equipment in the industry which is easy to understand, easy to operate, easy to service and backed by solid customer support.

Knight's Solution Center holds four 2-liter (1/2 gallon) containers of concentrate in a lockable, enclosed cabinet for ease of use and safety.

Large push buttons with locking tabs activate the delivery of diluted product. Dial-4 selectors allow the choice of any of the four products for both spray bottle and bucket fill applications. All plumbing is installed and the unit ready to hang on the wall for immediate use. Order with our K'Nect closed loop caps on the chemical supply lines or the traditional pickup lines with foot valves.

MX SOLUTION CENTER

- Separate Bucket Fill & Bottle Fill Selectors
- Pre-Plumbed with Water & Supply Lines
- Locking Doors
- Viewable Product Levels
- Flow Regulator Built-In
- Easy Mount Wall Bracket
- Large Paddles

MX Plus

- Tool-less Components - ¼ turn connections; double O-ring design.
- Snap-on Cover
- Large, easy-to-use paddles with locking catch
- Engines slide into snap-guides for easy service and re-configuration
- Easily serviced diaphragm with ¼ turn cover
- Compact footprint
- Both Aire-Gap and Flex-Gap backflow devices to meet national and local codes

The MX Plus family of dispensers are the industry's most field serviceable and flexible proportioner system. Available in an assortment of configurations around one, two, and three engine cabinet designs.



THE MX PLUS DIFFERENCE

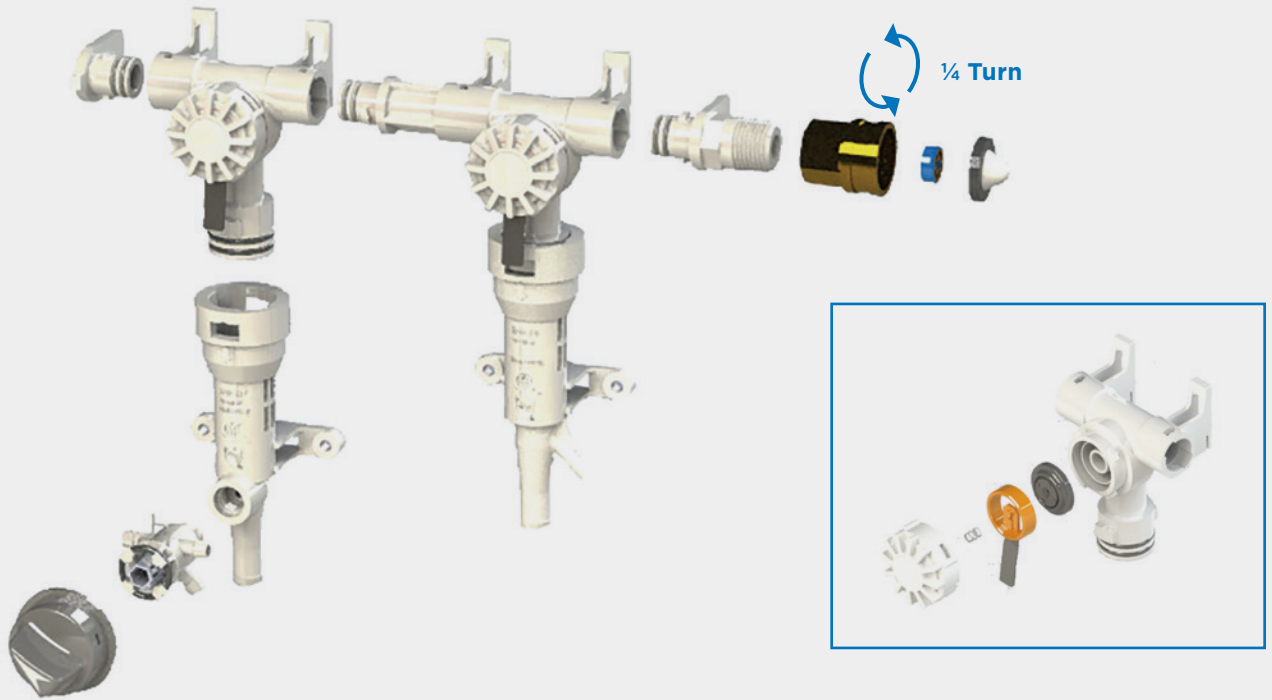

MX Hospitality

- Modular Design - can be daisy chained
- Flexible Configurations
- Economical
- Small Footprint



Simple, reliable, and versatile characterize Knight's MX Hospitality dispensers. All are modular and feature one engine per cabinet. Covers snap on and off for easy service. Daisy chain together for any number of desired products combining single product with Dial-4 dispensers in either low flow bottle fill or high flow bucket fill.



MXC - Corrections

When security and safety are paramount... Knight offers stainless steel cabinet options for 1 or four products which are housed within a locking cabinet. Choose fill rates to accommodate either bottle fill or bucket fill.





Sink Mate Plus

Knight's Sink Mate Plus brings the serviceability of our ¼ turn fittings together with a stainless-steel cover and quarter turn shut-off valves for kitchen applications.



Sani-Clean 3

The Sani-Clean 3 spray sanitation system accurately dilutes concentrated cleaners and sanitizers and dispenses the ready-to-use product through a hose. Use the foam attachment for degreasers and detergents, change the valves to use the hose to rinse, and then turn the valves again to dispense sanitizer. Stainless steel cover is durable and easy to clean. The unit comes with an assortment of metering tips.



Portable Foamer

A simple, easy-to-use hose foamer accurately dilutes chemical concentrates using the enclosed metering tips to deliver a rich foam for easy cleaning. Simply disconnect the sprayer from the hose gun by pulling back the quick-connect ring to rinse. The 1-liter (34 oz.) concentrate bottle allows ample cleaning time while staying light preventing arm strain.



K'Nect Closed Loop

K'Nect - the intelligent closed loop system delivers the safety and ease of use inherent with all closed loop systems but additionally finally solves the problem of consistent and accurate dilutions for both low flow spray bottle fill and high flow mop bucket filling.

Knight's patented design uses a floating poppet that adjusts to the varying vacuum draw created by different flow rates. Up till now, a bottle fill dispenser would pull almost double the amount of concentrate than a bucket fill dispenser when using the same tip. Knight's intelligent design compensates with a moving poppet that adjusts to the varying vacuum rates providing the correct dilution every time. This floating design coupled with two precise laser drilled metering holes guarantees accurate dilutions regardless of the flow rate. The single straw makes insertion into the bottles easy and fast. No more separate metering tips! Inserts and caps are available in a variety of colors and a wide range of dilutions.

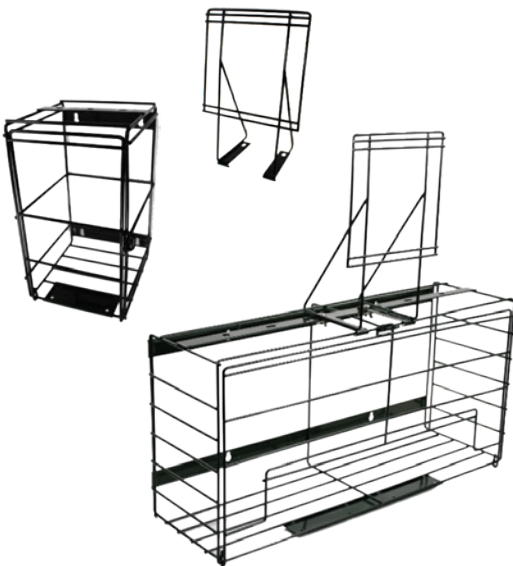

Container Storage

Knight offers a variety of solutions to keep chemical containers secure and off the floor. Choose from wire racks or locking enclosed cabinets.



Dual Cabinet with locks



Single Cabinet with locks



KNIGHT[®]
*Trusted Solutions,
Making Cleaning Easy*[™]

FOR MORE INFORMATION:

15340 Barranca Parkway
Irvine, CA 92618-2215

(800) 854-3764
Fax (949) 595-4801

www.knightequip.com
cs.knight@idexcorp.com

